

The Invention and Early History of the CCD

Dr. George E. Smith

To be Covered

Bell Labs Background

CCD Invention

Device Basics

Early Devices

Applications

Magnetic Bubbles

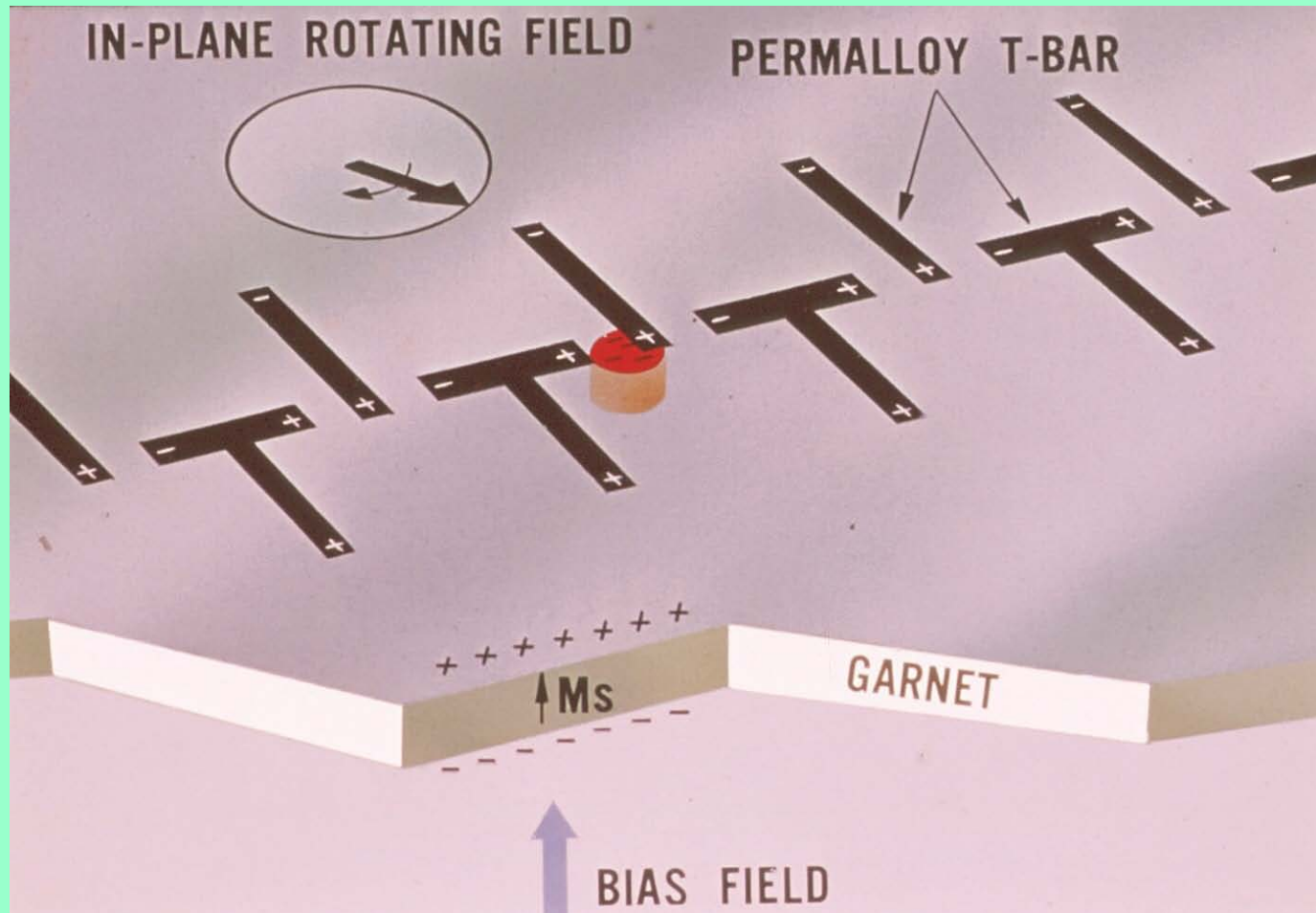

Picturephone

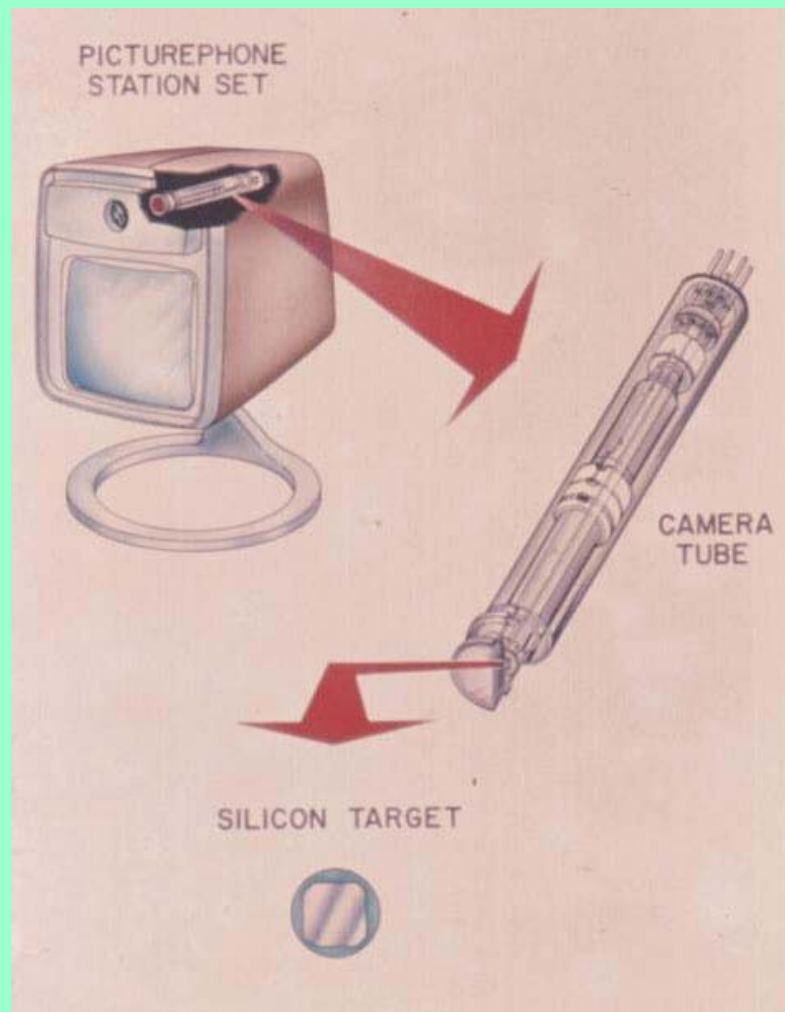

MOS Capacitor

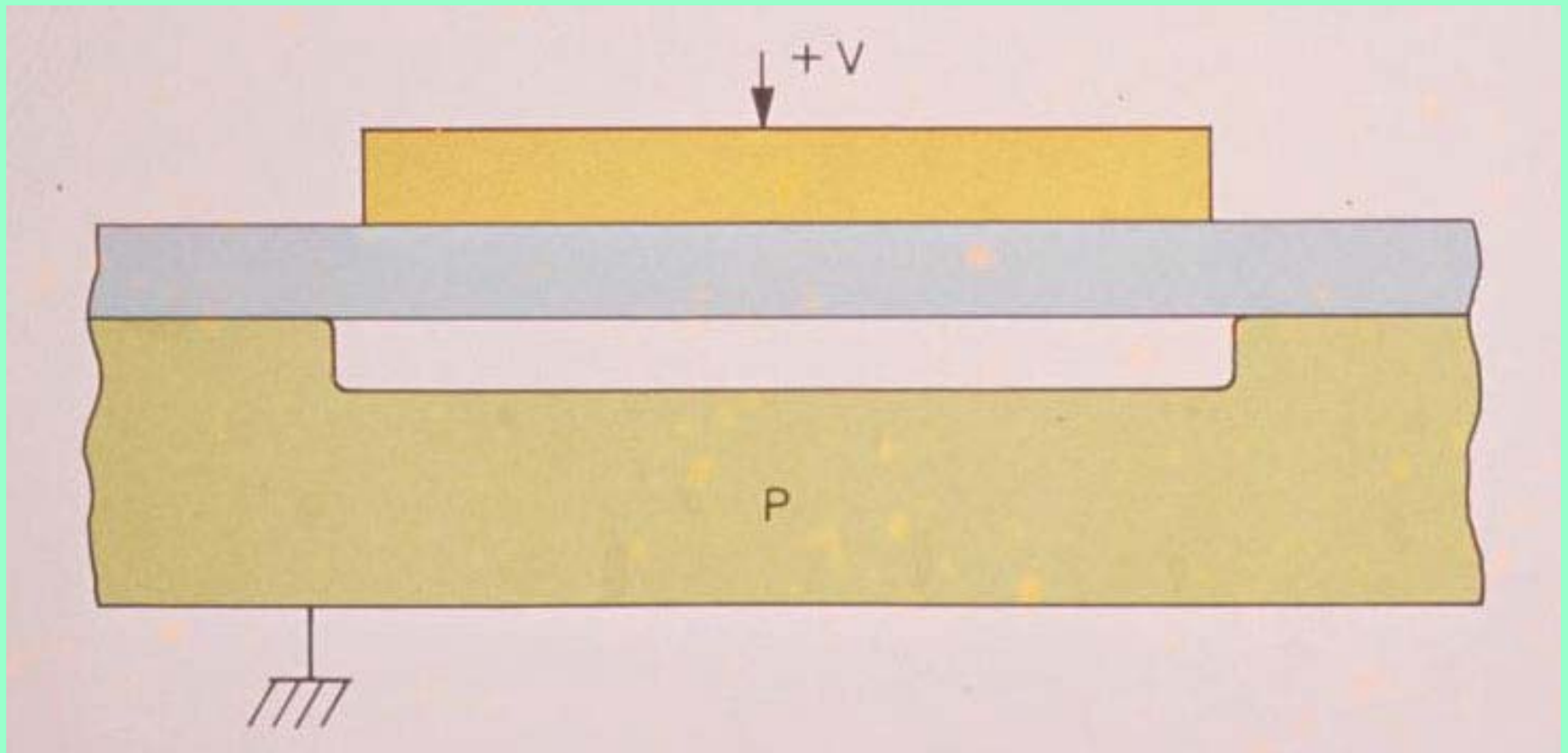

MOS Energy Diagram

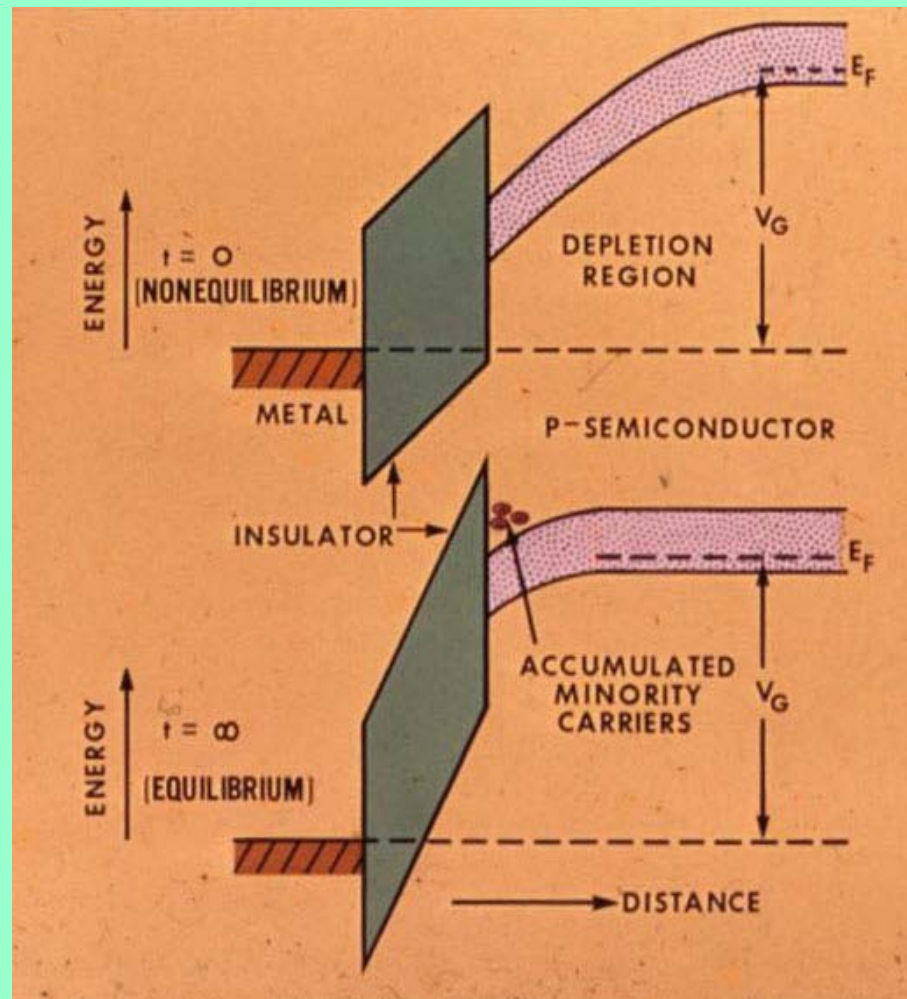

Two MOS Capacitors

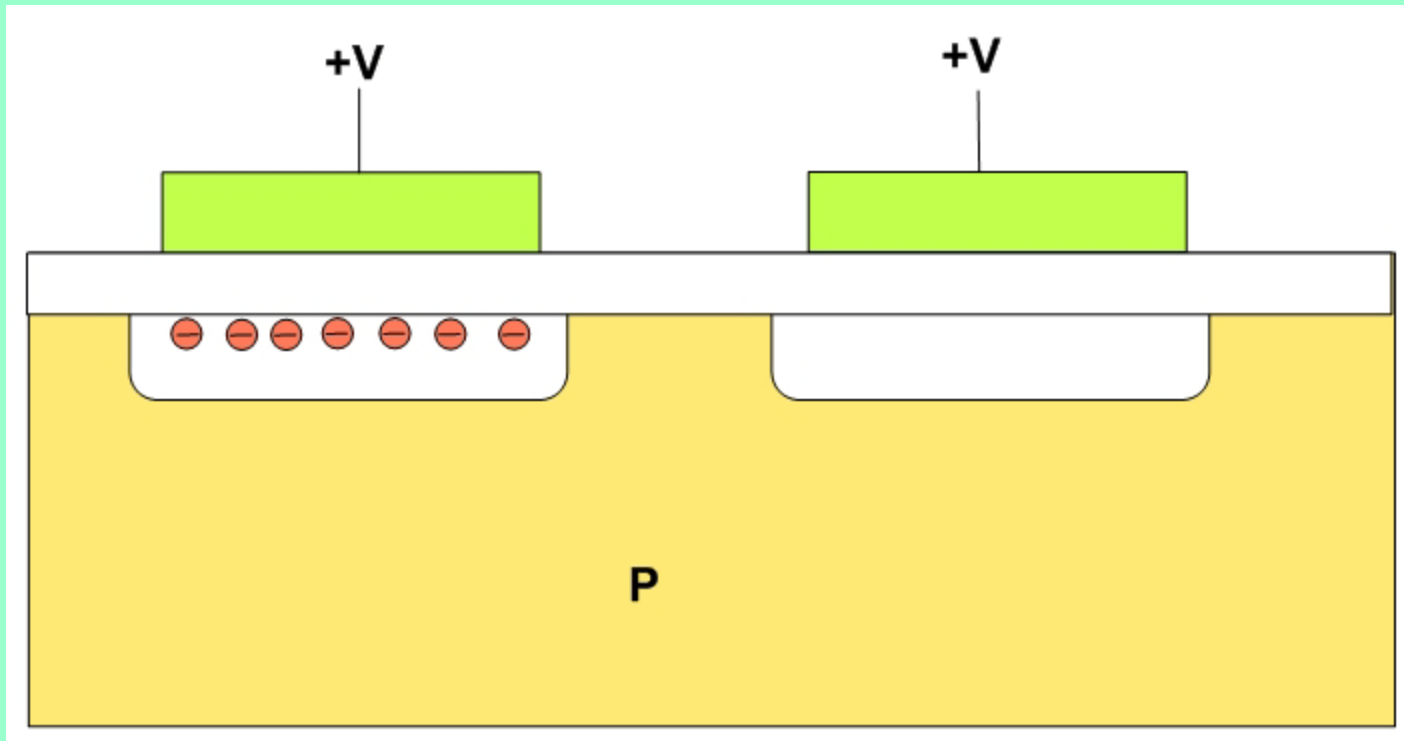

Three Phase CCD

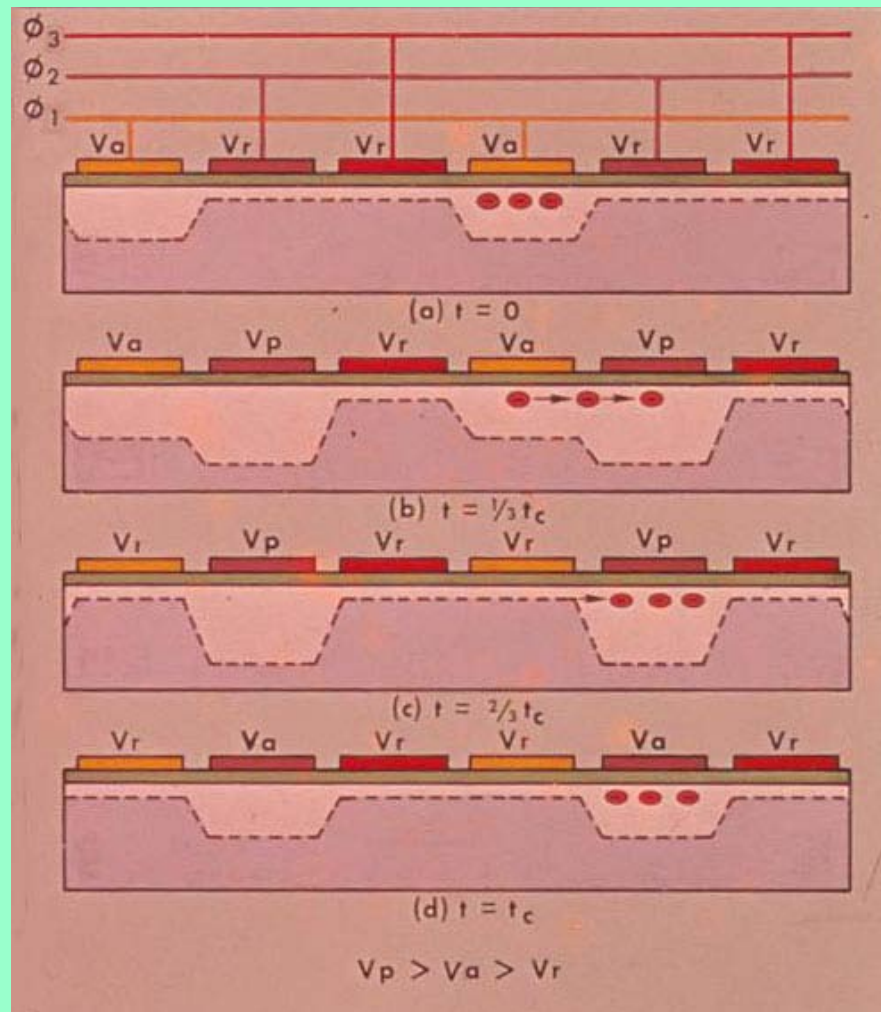

First CCD

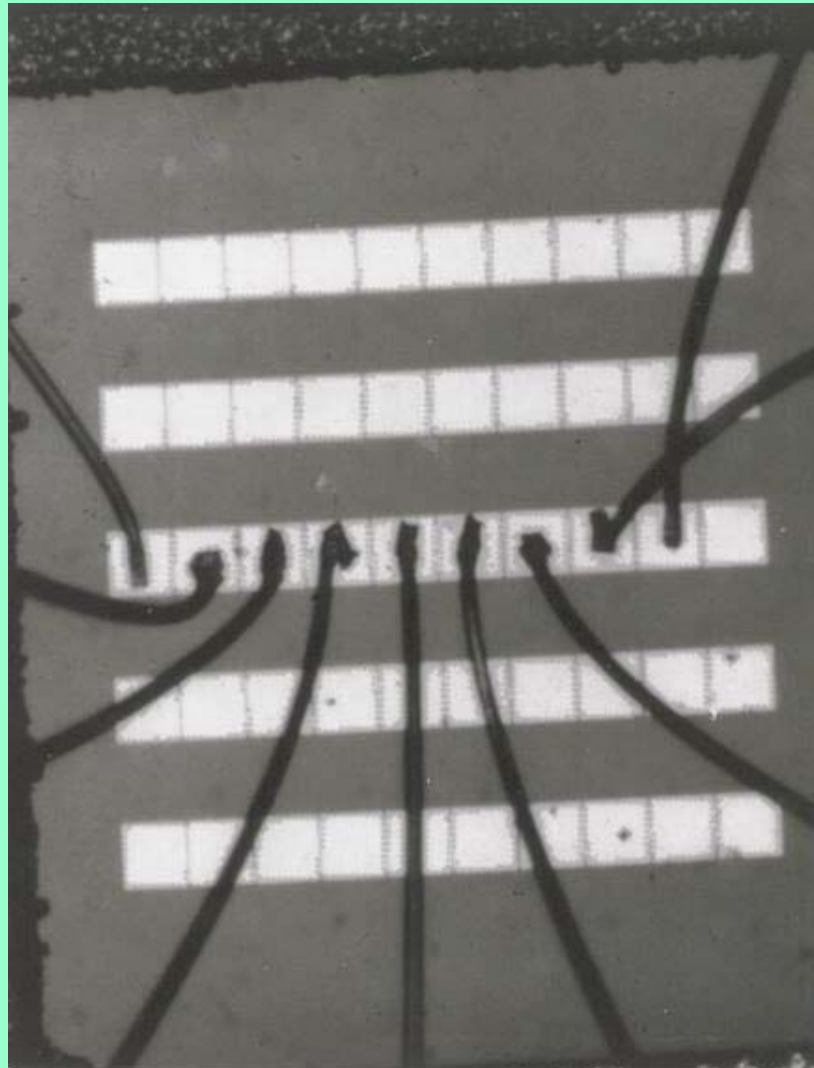

First Functional Device

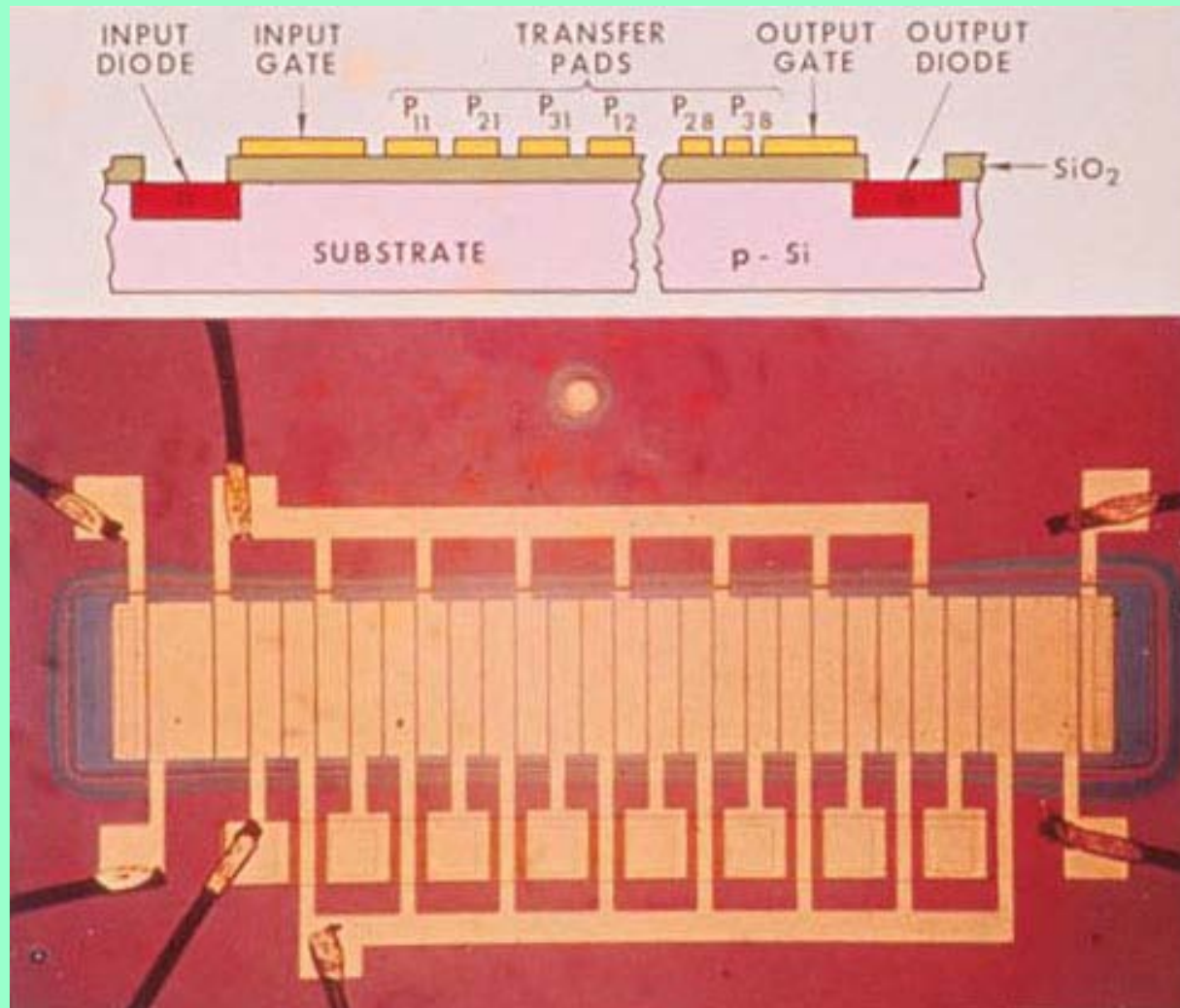

First CCD Image

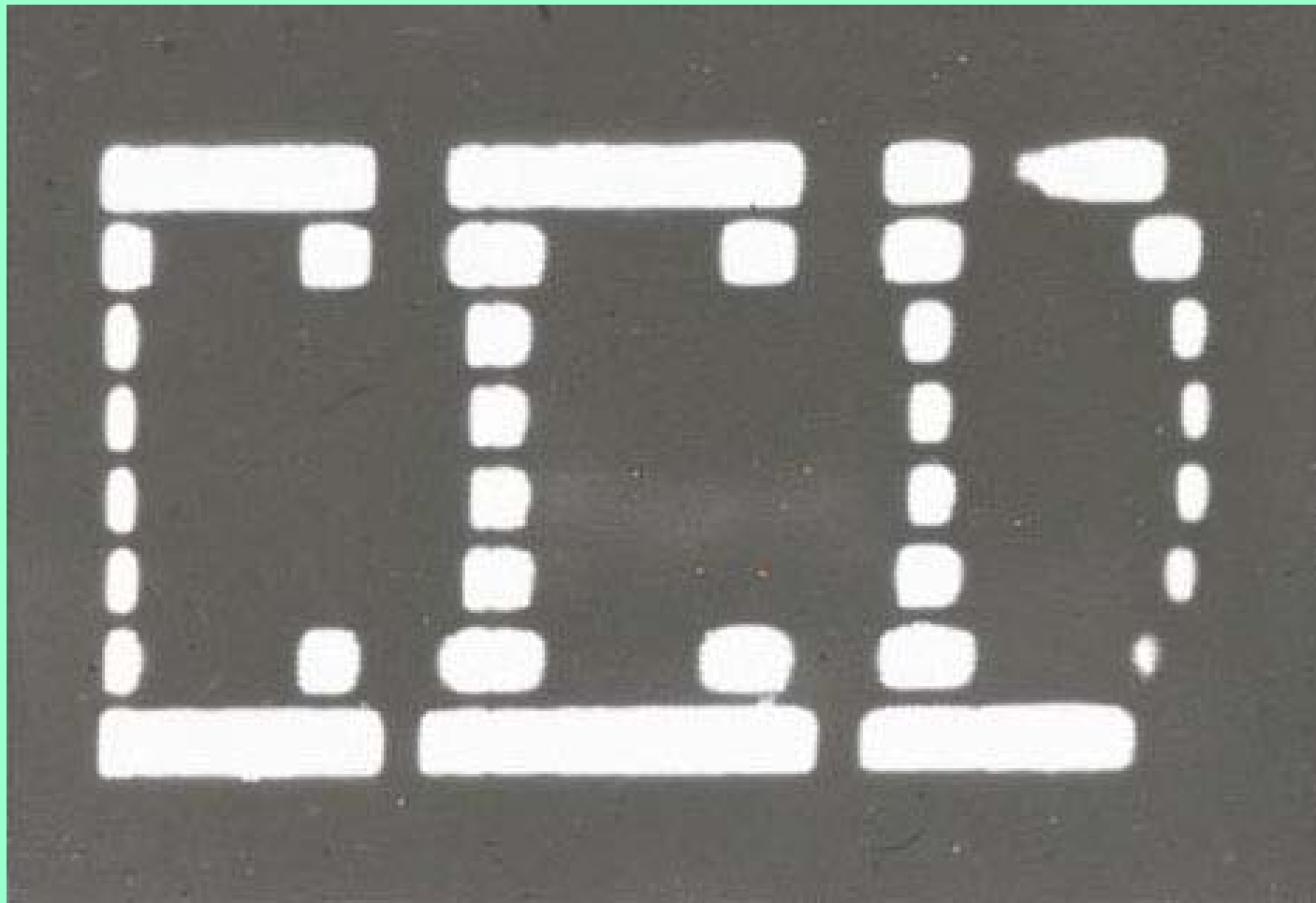

MOS Energy Diagram

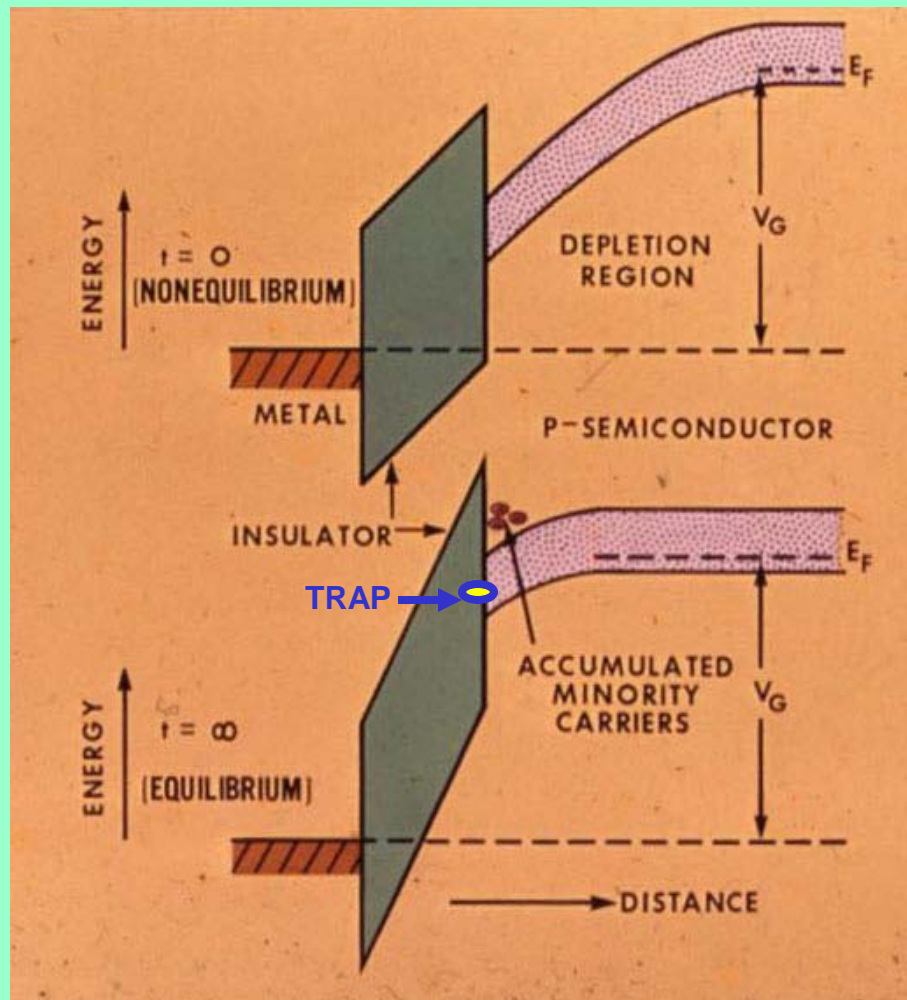

Buried Channel CCD

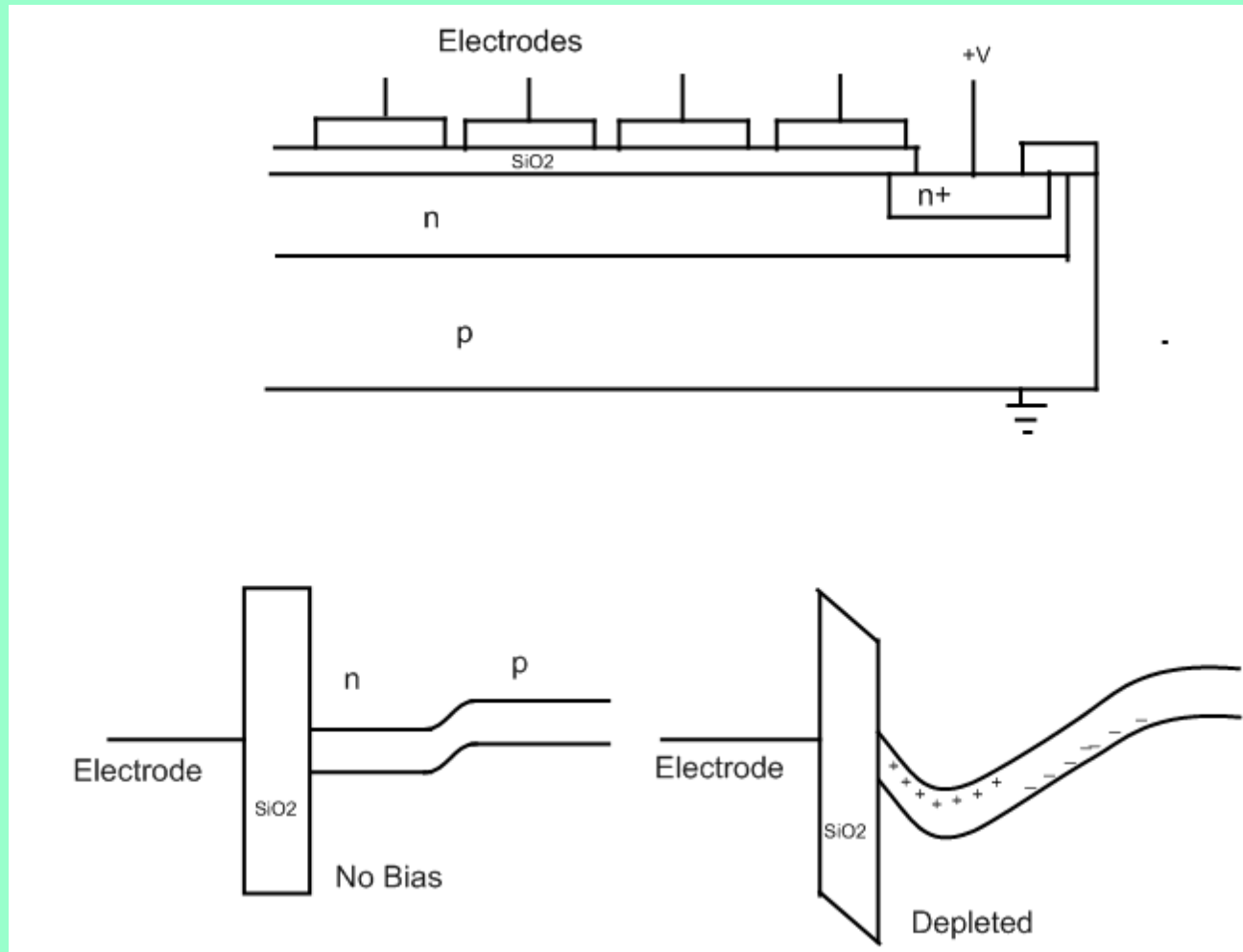

Area CCD

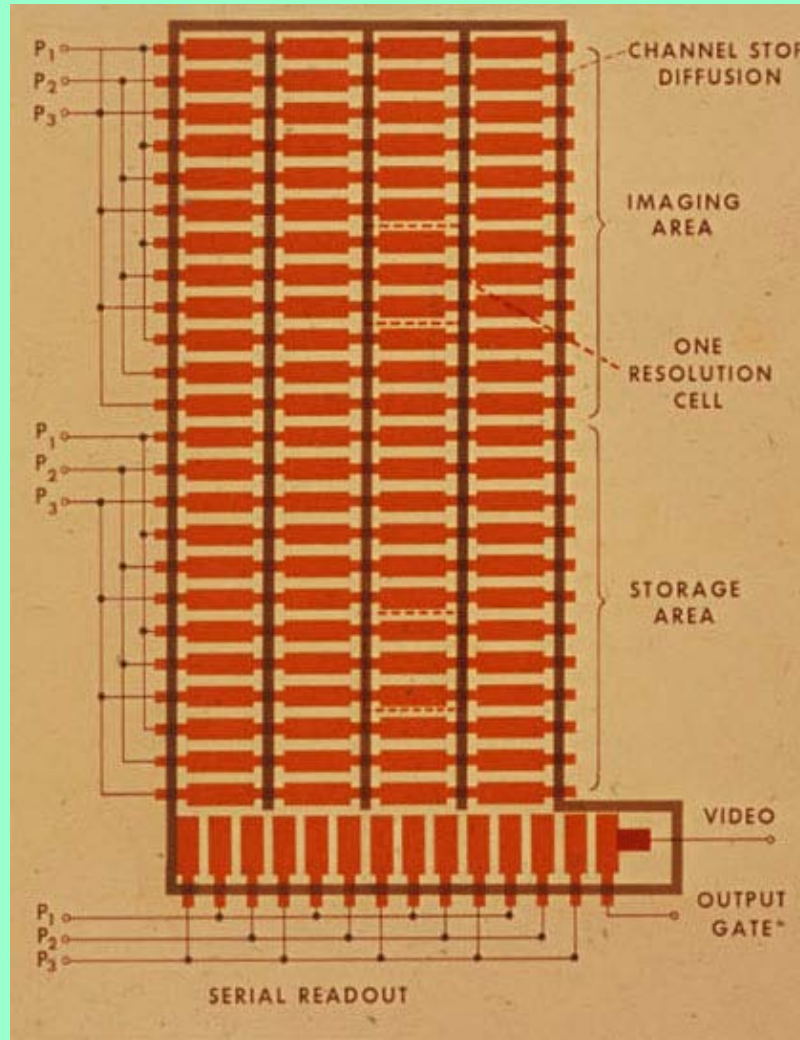

First Self Contained Camera

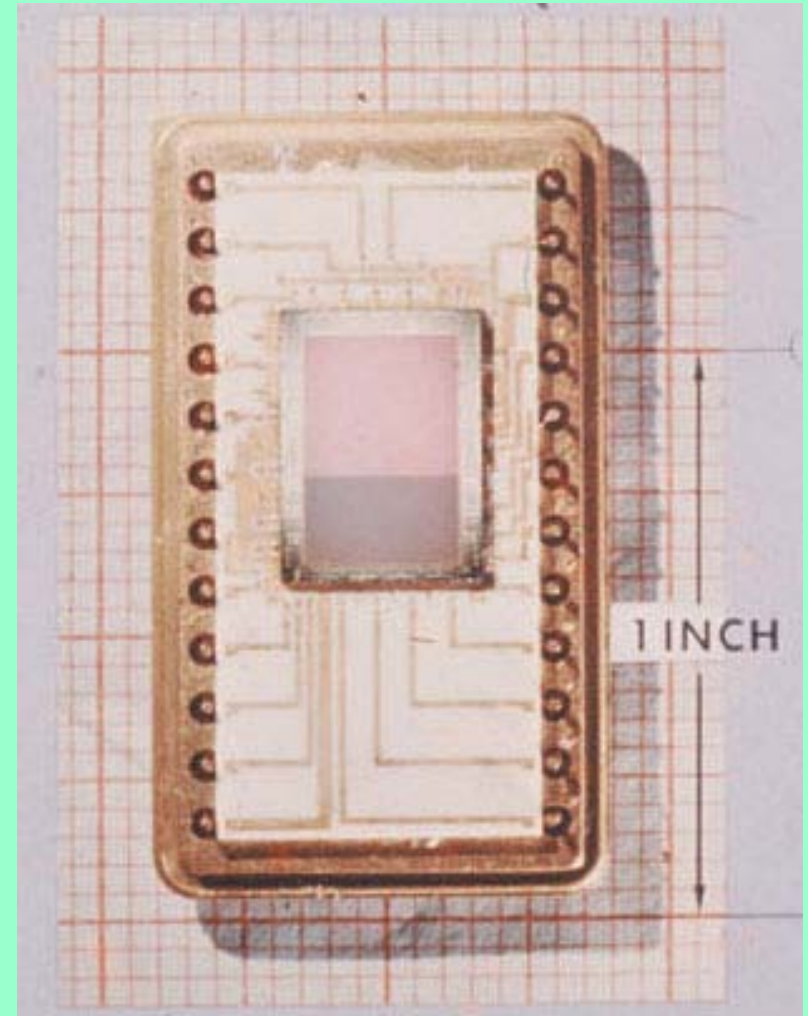

Linear CCD

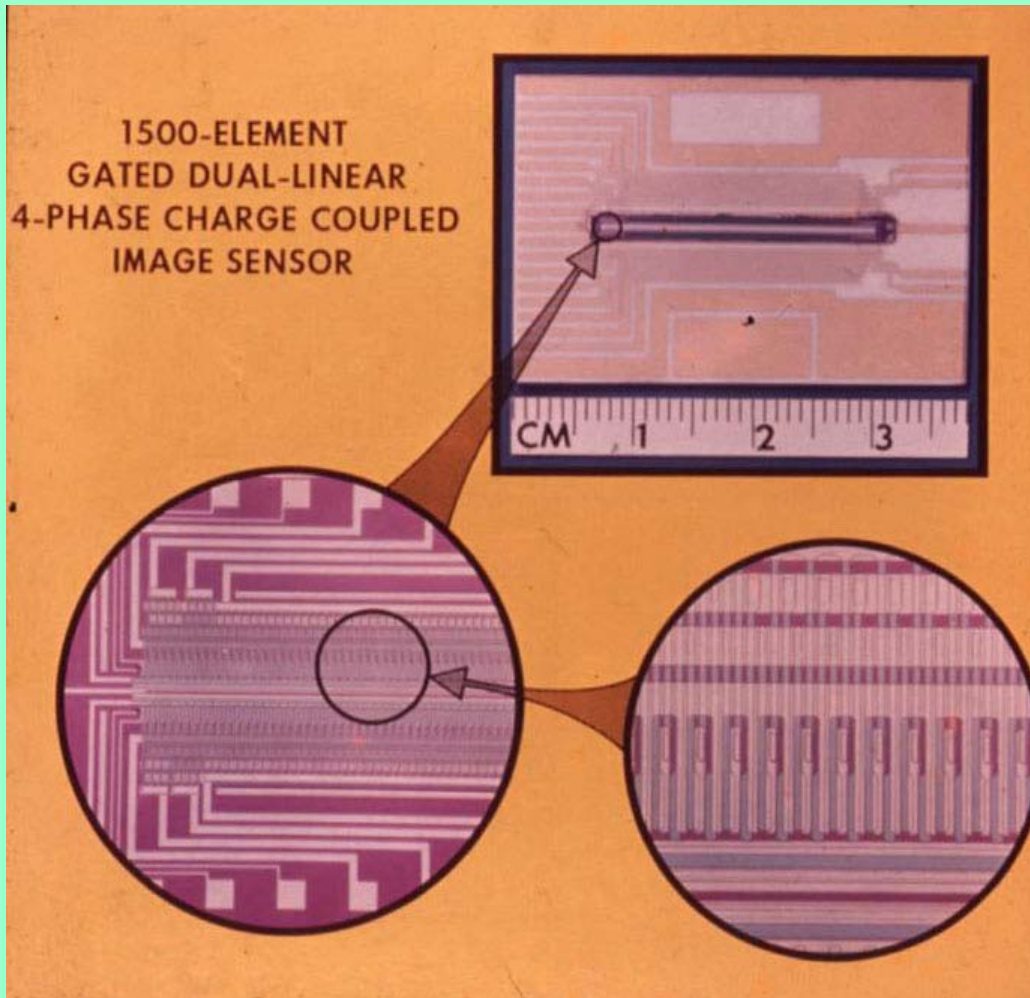

Linear Scan

Meet the new Omega. If you think you can't afford an Olds, think again.

A smaller Olds at a lower price.

Omega is a whole new kind of Olds—a compact, but one with Olds' big-car thinking built into three interesting variations: 2-door coupe, 3-door hatchback and 4-door sedan. All of them a lot of Olds for the money.

Omega is not your basic little car.

It's nearly 500 pounds more car than some smaller compacts. The wheelbase is longer—111 inches. And you can feel this extra size and heft working for you on the road. It's solid and steady. Roomy.

Comfortable. Agile and maneuverable.

You get what you bargained for.

Omega gives you nice things you may have to pay extra for in other compacts. A deluxe interior with new "wet look" vinyl trim. Full carpeting. Chrome trim around the windows and wheel openings. And 230 cubic inches of engine. There are

also things some compacts don't offer at any price! A glove compartment with a door and a lock. Rear windows that roll down. And generous trunk space.

Add some neat ideas of your own.

You can order a vinyl roof for looks. Our famous Rocket 350 V8 for gas. Sporty high-back bucket seats and a console for the coupe and hatchback. Even a special tent that converts the hatchback into a camper.

It feels like a bigger car.

Get into an Omega and notice the comfort. The way you sit up, how right the steering wheel position seems, how easily the car responds. Sure, you can get a lesser compact for less money—but then, it wouldn't be an Olds Omega Oldsmobile. Always a step ahead.

'73 Oldsmobile Omega.



Aerial Photo

LINEAR IMAGE SENSORS
APPLICATION: AERIAL
RECONNAISSANCE

FAIRCHILD

6114

CCD121
1728 x 1 SENSOR IN

FAIRCHILD MINI-CAMERA

TAKEN AT:
2000 ft. ALTITUDE
150 KNOTS OVER
SOUTHERN LONG ISLAND

PHOTO REPRODUCED FROM
STORED DATA BY LASER
RECORDING PROCESS



Current Applications

Digital Cameras

TV Cameras

Scanners

Medical devices

Fax machines

Bar Code Readers

Satellite Surveillance

Earthly Surveillance

Astronomy

CCD's in Astronomy

90% Quantum Efficiency (Film is 5%)

Long integration times (at 160° K) 20 electrons/hr/pixel)

Large dynamic range 10^5 electrons/pixel

Repeatability eliminates systematic errors

Astronomical Camera

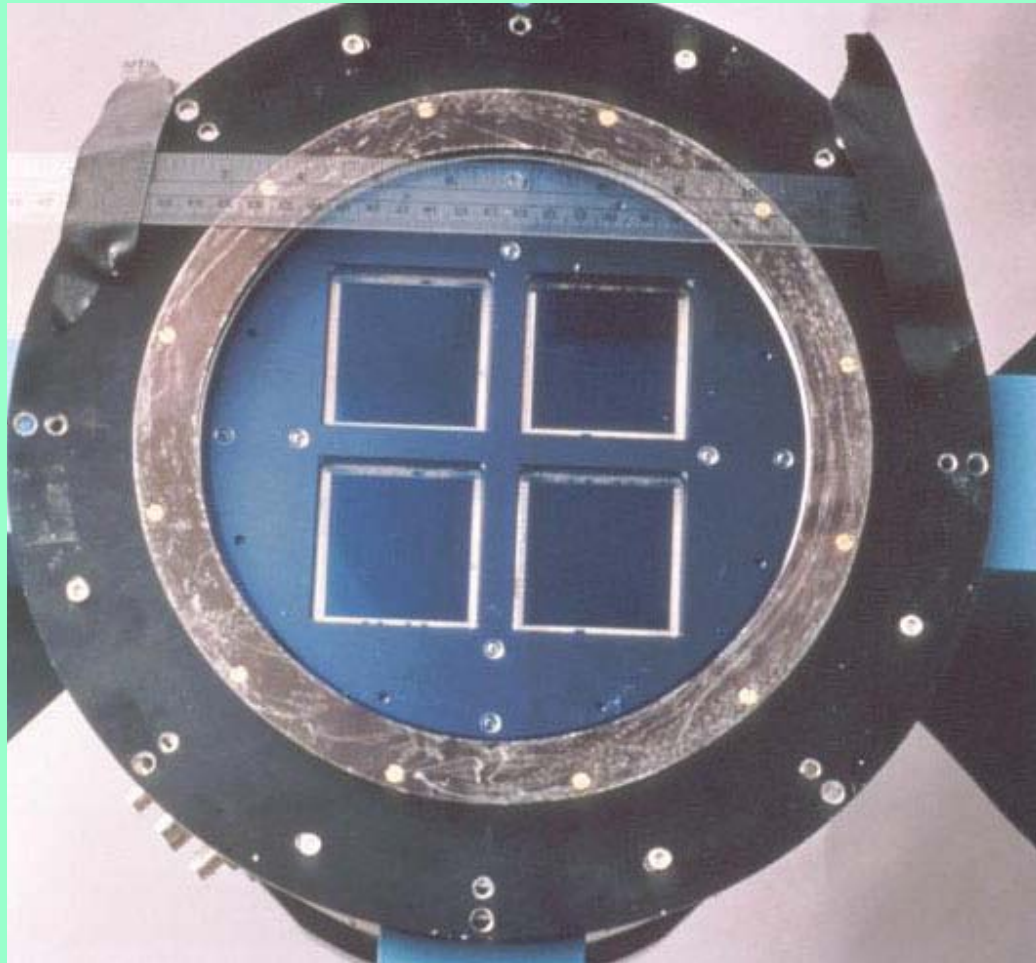

More Before & After

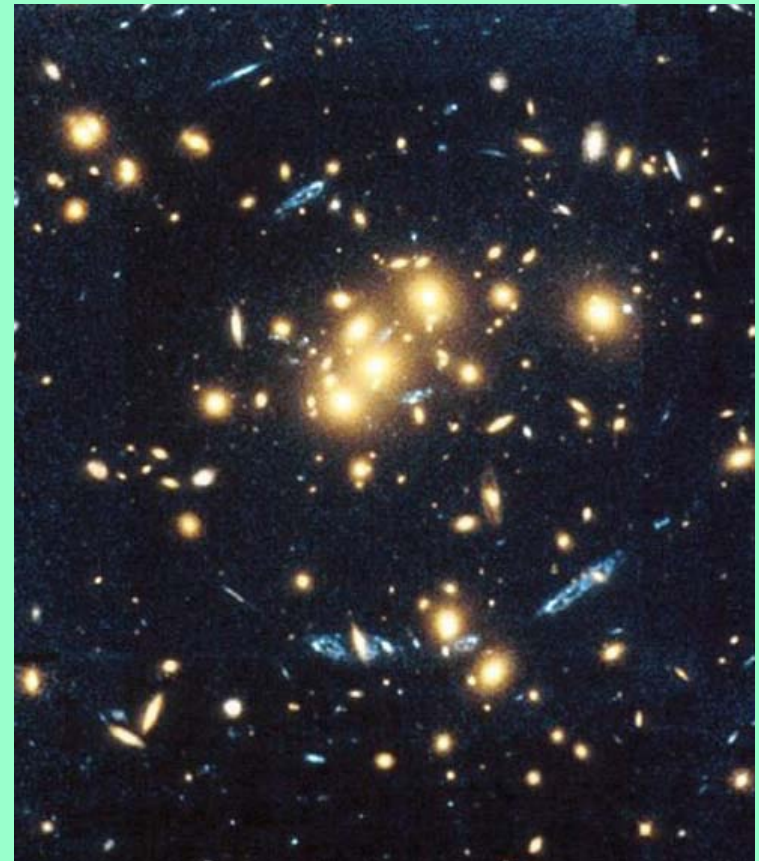
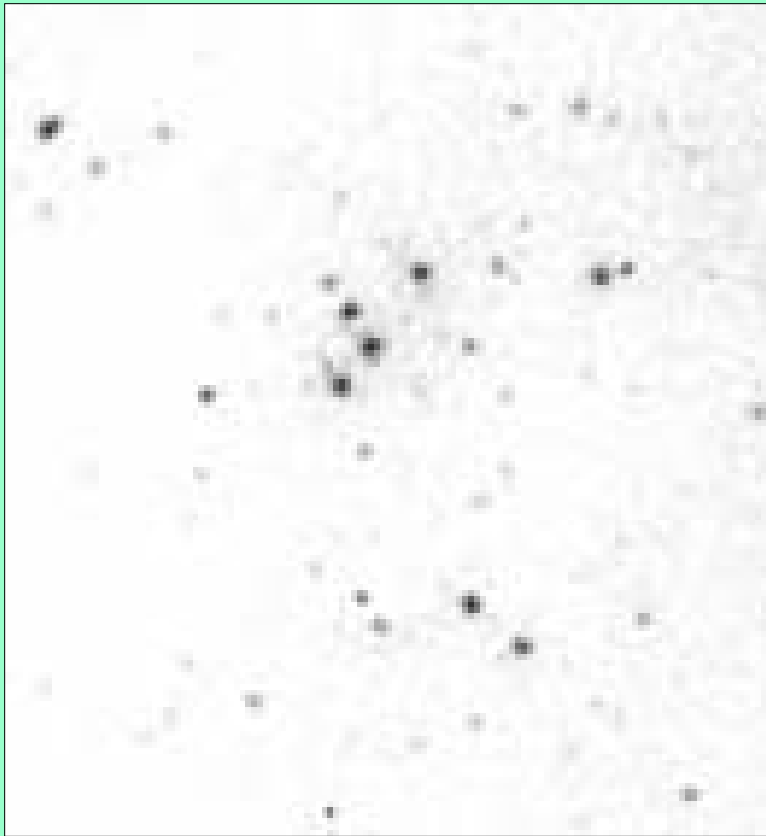

Summary

CCDs born in the Si-SiO₂ Revolution

1st Practical Solid State Imaging Device

Widespread Applications