

ELECTRONIC IMAGING OF IONIZING RADIATION WITH LIMITED AVALANCHES IN GASES

Nobel Lecture, December 8, 1992

GEORGES CHARPAK

CERN, Geneva, Switzerland

Detecting and localizing radiation is the very basis of physicists' work in a variety of fields, especially nuclear or subnuclear physics.

Certain instruments have assumed special importance in the understanding of fundamental phenomena and have been milestones in the building up of modern theories. They make up a long list: the ionization chamber, the cloud chamber, Geiger-Müller counters, proportional counters, scintillation counters, semiconductor detectors, nuclear emulsions, bubble chambers, spark and streamer chambers, multiwire and drift chambers, various calorimeters designed for total absorption and then measurement of particle energy, Cherenkov or transition radiation counters designed to identify or select particles, and many other detectors, some very important examples of which are still being developed. However, some of this equipment has become obsolete as physicists' requirements have changed. Wire and drift-chambers, introduced in 1968, met the then requirements of physicists, whereas the properties of the most productive detectors available at the time, mainly bubble and spark chambers, were no longer capable of meeting those needs.

Multiwire chambers gave rise to further developments in the art of detectors, of which some are highly innovative. Most high-energy physics experiments make use of these methods, but their application has extended to widely differing fields such as biology, medicine, and industrial radiology.

Our study of multiwire proportional chambers, which began in 1967, was triggered by the problems with spark chambers which then faced us. The latter, introduced in 1959 by Fukui and Myamoto, beautifully supplemented the bubble chamber. Whereas the latter was still peerless in the quality of the information which it provided and from which one single exposure could on its own lead to an interesting discovery, the spark chamber gave a repetition rate more than 100 times higher. Moreover, as it had a memory of almost $1 \mu\text{s}$, the instrument could be triggered only for events selected by faster auxiliary counters, making it possible to address the study of phenomena which occurred much more rarely in very high-energy interactions. Nevertheless, the need to store the information on photographic films led

to a bottleneck: beyond a few million photographs per year or per experiment, the exposure analysis equipment was saturated.

Physicists therefore had to invent methods of reading the sparks which bypassed photographs. We introduced two new methods: one was based on the measurable delay of the signal produced by a spark in reaching the end of an electrode; the second, based on the division of the current produced by a spark in plane or wire electrodes, at the ends of which the current pulses are measured, made it possible to obtain the coordinates of the spark and hence of the particle by purely electronic means. This latter method was developed in several laboratories for the focal planes of spectrometers and we have ourselves thus performed experiments on the nuclear reactions induced by pions.

Other approaches, some of them better than ours, were developed simultaneously: sonic spark chambers and wire spark chambers which gave rise to very important developments. Nevertheless, the fact that it is impossible to trigger spark chambers at rates above about 100 times per second reduced their scope. In the minds of some physicists arose the idea of limiting the discharge produced from electrons released in a gas to a much lower level than that attained by the spark so as not to discharge the capacitance formed by the electrodes; the additional gain thus needed was to be obtained by means of electronic circuits.

In 1967, I undertook this step, armed with some experience acquired at the College de France from 1948, some ten years before I joined CERN. I built cylindrical single-wire proportional chambers and also demonstrated the possibility of making use of the light phenomena produced by an avalanche of electrons in a gas. This approach led to no practical method. It was greatly extended later on during work done at the University of Coimbra in Portugal by E. Policarpo. This work, from which I drew a great deal of inspiration, proved very valuable for the experience I gained and, more particularly, the understanding of the principles governing the multiplication of electrons in gases. It led me to an attempt to build chambers with avalanches made visible by short electric pulses. It resulted, in 1956, in the first detector with sparks following the trajectory of particles. It played no role in the introduction of spark chambers in particle physics.

Figure 1 shows the design selected in 1967 to study proportional multiwire structures.

A study of the electric fields shows that, in the region near the wire taken to a positive potential, where a limited-scale avalanche is to be produced, the electric field is the same as that prevailing near a wire tensioned in the axis of a cylindrical tube, as can be seen in figs. 2 and 3. With the parameters we chose, in a gas in common use in proportional counters, the average mean free path of an ionizing collision should, at atmospheric pressure, be about $1 \mu\text{m}$ (fig. 4). We might therefore expect a gain of about 10^5 for an avalanche extending over a distance close to the diameter of the wire, i.e. $20 \mu\text{m}$.

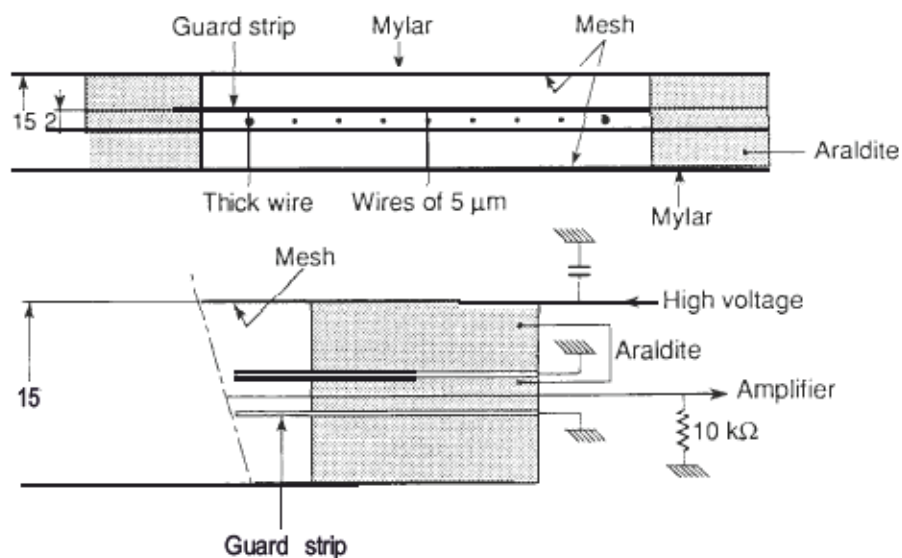

Fig. 1: A few construction details of multiwire chambers. The sensitive anode wires are separated by 2 mm from each other, their diameter is $20\ \mu\text{m}$. They are stretched between two cathode meshes, in a gas at atmospheric pressure. The edges of the planes are potted in Araldite, allowing only the high voltage to enter and only the pulses to leave to a $10\ \text{k}\Omega$ amplifier.

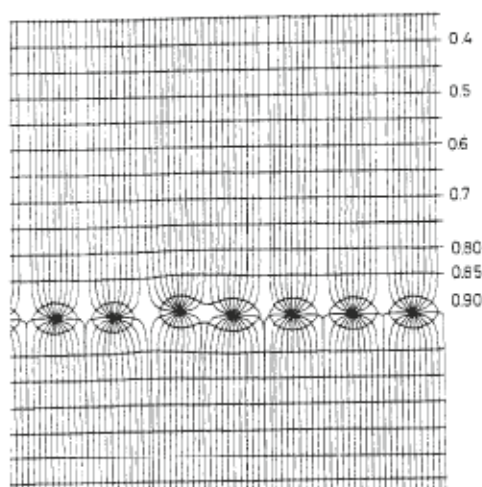

Fig. 2: Equipotentials and electric field lines in a multiwire proportional chamber. The effect of the slight shifting of one of the wires can be seen. It has no effect on the field close to the wire.

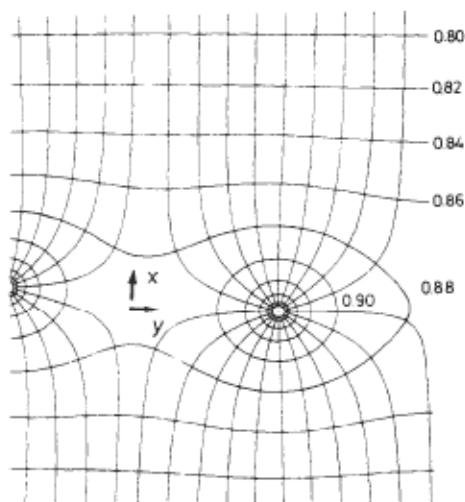

Fig. 3: Detail of fig. 2 showing the electric field around a wire (wire spacing 2 mm, diameter $20\ \mu\text{m}$).

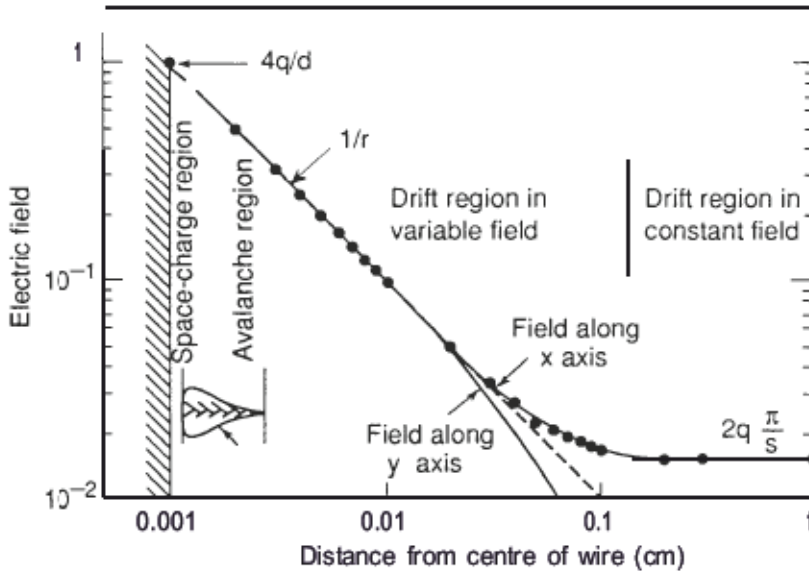

Fig 4: Variation in a proportional chamber of the electric field along the x axis perpendicular to the plane of the wires and centred on one of them, and in the y direction parallel to this plane. The various regions (electron, avalanche and drift space in a variable and then constant field) are shown.

There still remained one challenging problem, that of the capacitive coupling between the wires. The closer they were, the more likely it was that a pulse induced in one wire would be propagated on its neighbours. This was true for pulses produced by an external electric generator but untrue for the internal generator formed by the positive and negative ions separating under the effect of the electric field. There had, in the past, been examples of wire counters, especially in cosmic-ray experiments, where this fear of coupling led to the insulation of each of the positive amplifying wires by partitions or thick intermediate wires. We merely have to examine the pulse-generation mechanism in a proportional counter to see that, whatever the distance between the wires, the one which is the seat of an avalanche will develop a negative signal, whereas the neighbouring wires and, in general, all the neighbouring electrodes, develop a positive signal which is therefore easy to distinguish from the other.

Most of the electrons produced in the first microns in front of the wire pass through a very small proportion, ΔV , of the potential V applied between the wire and the cathode on their trajectory. The collected charge Q will produce on the wire taken to the potential V only a pulse of charge ΔQ , so that $V \cdot \Delta Q = Q \cdot \Delta V$. With our selected parameters, the time needed to collect the electron charge was a fraction of a nanosecond. However, the positive ions have to pass through the whole of the potential drop V and thus induce almost all of the charge pulse which develops as a function of time according to a law which reflects the considerable field close to the wire and the decreasing field far from it. The initial very fast increase of the

pulse gave some people the illusion that the initial pulse observed was caused by the collection of the electrons of the avalanche. For a proportional counter with a radius of 1 cm, and a wire with a diameter of 20 μm , the electron contribution is only 1 %. Figure 5 shows the characteristic shape of the development of a pulse in a proportional chamber owing to the motion of the ions. Although the total time taken for ion collection is close to 500 μs in the example chosen, almost half of the signal develops within a time close to a thousandth of this value, which is very useful for fast detection.

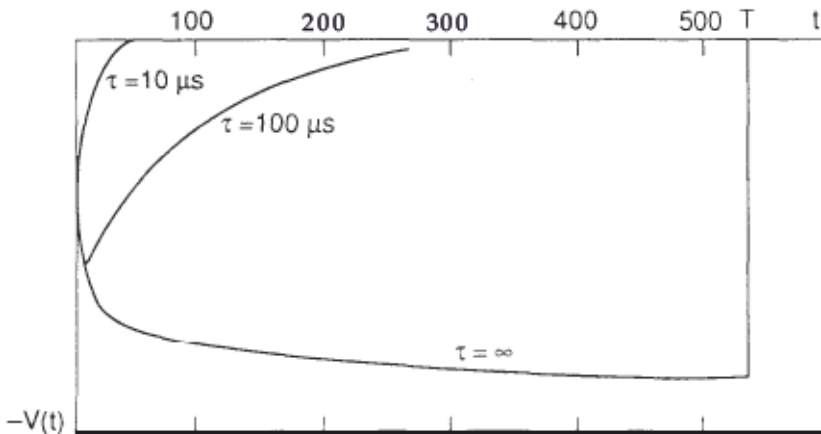

Fig. 5: Development in time t of a pulse in a proportional chamber; T is the total drift-time of the positive ions between the anode and the cathode. The effect of decreasing differentiation time constants τ is seen. The motion of the positive ions close to the wires produces a very fast-rising pulse.

The key phenomenon is this: whereas the induced signal is negative on the wire from which the positive ions are going away, it is positive on the neighbouring wires or electrodes.

This has two important consequences:

- It is a simple matter to locate the wire which is the seat of the avalanche, whatever the distance between the wires.
- The position of this avalanche along the wire can be obtained if the cathode is made of wires or strips perpendicular to the anode wire.

The distribution of the induced positive signals is then centred on the avalanche. Experience was to show that this observation was of prime importance to the imaging of neutral radiation, photons, or neutrons.

The time resolution of the detector depends on the distance between the wires. Proportional cylindrical chambers had been abandoned in particle-physics experiments as this resolution was poor: the time taken by the electrons released in the gas to reach the multiplication region near the wire is actually variable. It immediately appeared that the delay was easily measured in a multiwire chamber and that it gave precisely the distance of the ionizing particle from the wire.

This cleared the way for a class of detectors derived from wire chambers in which the detecting wires are very far apart and where the coordinate is calculated by measuring the drift-time of the electrons in the gas. From 1968 we showed that it was possible to obtain accuracies of the order of $100\ \mu\text{m}$ with structures such as that of fig. 6, which provide a constant electric field over a long distance. In 1969, a group at Saclay began to build drift chambers with a migration length of 20 cm, while, in Heidelberg, studies were undertaken on chambers constructed, similarly to ordinary wire chambers, with a field wire fitted between the anode wires to repel the electrons. The drift chamber seemed to be the ideal instrument for large detectors; many were the groups which then began to fit considerable areas with these detectors, reaching, for instance, $5\ \text{m} \times 5\ \text{m}$, making possible a precision of a few hundred microns, with electronics comprising a limited number of channels.

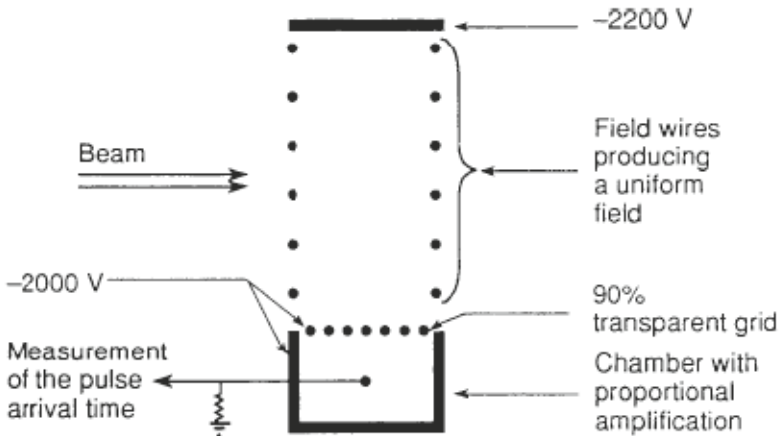

Fig. 6: Operating principle of a detector based on the drift-time of the electrons in a constant electric field (1968).

Starting in 1969, we stressed that the exploitation of electron drift in large volumes, combined with the measurement of the centroid of the avalanches induced in a wire chamber, was the way leading to three-dimensional detectors. It was, however, D. Nygren who, by combining the effects of parallel magnetic and electric fields and solving formidable data acquisition problems, succeeded in creating an instrument which provides the finest images of the most complex configurations obtained in colliders; for this purpose the repetition rate must be low enough to accommodate an electron drift over long distances. In fact it was the demands of physics, differing very widely depending on the nature of experiments and accelerators, which dictated the structures of gas detectors, making use of the properties that we demonstrated in 1968.

The development of transistor electronics, however, made it possible to

design systems requiring tens of thousands of channels. The advantage of wire over drift chambers was their capacity of accepting very high counting rates. The resolution time, of about 30 ns, and the possible counting rate of 10^6 pulses per second, made it feasible to tackle the study of rare phenomena which were beyond the reach of spark chambers as they needed very high counting rates.

The design study of a giant detector, the Split-Field Magnet (SFM) was launched at CERN in 1970 under the direction of A. Minten for an experiment at the Intersecting Storage Rings (ISR). This detector comprised 70,000 wires, some of them 2 m long. Another group under J. Steinberger undertook the construction of a detector designed to collect a large number of events violating charge parity conjugation in the study of kaon decay. A large number of difficult problems had to be solved to go from the $10\text{ cm} \times 10\text{ cm}$ chamber to these large areas. The intensity of the pulses collected on the wires of a chamber was proportional to the energy deposited in the volume defined by the electric field lines ending at a wire. In a cylindrical counter, simple considerations showed that the logarithm of the gain was proportional to a factor $\text{off} = V^{1/2}[(V^{1/2}/V_1^{1/2}) - 1]$, where V is the applied voltage and V_1 the threshold voltage. The behaviour of the wire chamber is exactly the same as that of a cylindrical counter.

My group was then reinforced by F. Sauli, who, together with collaborators joining the various projects launched by us, contributed greatly to the success of many new detectors. We undertook a systematic study of the factors controlling the accuracy in drift chambers. We investigated the ultimate accuracy which can be reached in multiwire chambers by measuring the signals induced on the cathodes. We showed that the avalanches could extend to only a very limited extent around the wire and that by measuring the centroid of the induced signals it was possible to determine the azimuth of an avalanche. Our results and those of a few others, which started a systematic study of the multiwire structures, led to a generalization of the use of wire chambers and drift chambers with a considerable diversification of the detector's structure best adapted to the variety of situations encountered in particle physics.

Mixtures of up to four gases were found to reduce the cost of the necessary electronics, making it possible to obtain high saturated pulses independent of the energy deposited in the gas, and required less sensitive and expensive electronics than with the proportional system, as well as being sufficiently resistant to ageing effects.

It was demonstrated that these pulses were produced by a series of avalanches which stopped at the uniform low field far from the wire.

A systematic study of chambers filled at very low pressures, conducted in Israel by A. Breskin, was to show that the chambers operated at pressures as low as 1 Torr with astonishing time resolutions: the range of application of wire chambers was widening.

Whereas wire and drift chambers were essential in all the particle physics experiments, rapidly replacing spark chambers and, in some instances,

reinforcing bubble chambers with structures outside them, many groups were making use of the new opportunities offered for imaging various types of ionizing radiation. The main applications appeared in the field of X-rays with an energy close to 10 keV. Under the inspiration of V. Perez-Mendez, chambers were built to study the structure of proteins by the imaging of X-rays diffracted by their crystals. Gas detectors had the drawback of being highly transparent to X-rays and the methods used to overcome this required compressed xenon.

We, on our side, tried to solve this problem by building a spherical drift chamber centred on the macromolecule crystal. The radial lines of the electric field eliminate any parallax and the electrons drifting over 15 cm are transferred into a 50 cm \times 50 cm multiwire chamber in which the avalanches are measured to a precision of 0.5 mm. It is also found that the response is continuous in both dimensions, as the diffusion ensures an expansion of the cloud of ionization electrons which always covers two wires, making it possible to interpolate the position of the avalanche between them.

The apparatus has considerable advantages over photography in terms of data-acquisition rate and the signal-to-noise ratio. Used routinely with the X-ray beams produced by the synchrotron radiation from an electron storage ring at Orsay it gives a good crop of important results.

The imagination shown by various groups has made it possible also to extend the field of application of wire chambers for higher X- or γ -ray energies.

Thus, a Novosibirsk group has developed a chamber making it possible to X-ray the human body with a decrease in dosage over the most powerful equipment available on the market of at least a factor of 10.

A group at Schlumberger has produced a system for radiographing giant containers using X-rays of up to 5 MeV. A. Jeavons has constructed positron cameras capable of detecting 0.511 MeV γ -rays with a precision of about 1 mm. These cameras, which are not efficient enough for the method to be applied to nuclear medicine, made possible a remarkable advance in the field of solid-state physics. Finally, a firm is now marketing a camera for γ -rays, competing with the Anger camera, which is specially suitable for use on children. Its principle is based on a wire chamber filled with compressed xenon. It gives a considerable reduction in the doses administered and also increased precision.

These few examples are enough to show that we may be on the threshold of the general use of radiation detectors originally invented for particle physics. It will develop in line with the progress made in particle physics research laboratories.

An important stage in the widening of the field of application of gas detectors was made with the introduction, by J. Seguinot and T. Ypsilantis, of photosensitive vapours. They make it possible to locate photons in the far ultraviolet of an energy above about 5.3 eV with a precision of less than 1 mm. Major instruments designed to identify particles through Cherenkov

radiation are now in use in some giant collider detectors. D. Anderson explored the opportunities provided by the detection of the photons emitted by scintillators. Figure 7 shows a 9 GeV photon spectrum obtained with a chamber containing a tetrakis(dimethylamine)ethylene (TMAE) vapour. Subsequent research also shows that it is possible to use condensed photocathodes compatible with gas amplification.

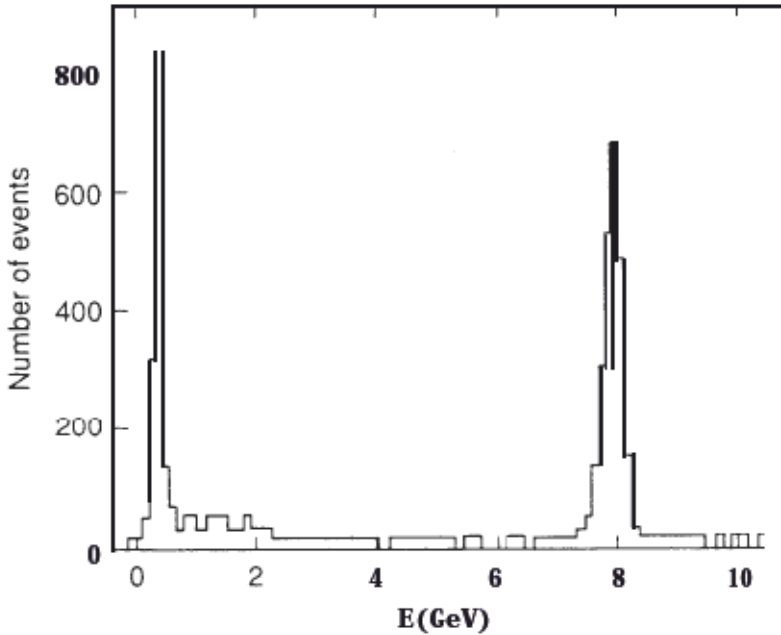

Fig. 7: Energy spectrum of 9 GeV particles (electrons and pions) with BaF crystals coupled to wire chambers filled with a photosensitive gas (TMAE, see text)

As the intensity of accelerators increased, it was found that the wire chambers themselves could not cope with the expected counting rates. Beyond particle fluxes from 10^4 to 10^5 hits per second and per millimetre of wire, the space charge produced by the accumulation of positive ions offset the applied field and annulled the gain.

To overcome this problem I thought, together with F. Sauli, of separating the gas amplification into two stages: a gain in a preamplification structure followed by a partial extraction of the electrons into a drift region fitted with a control grid, and their transfer into a wire chamber which would be required only to amplify the electrons accepted by the grid (fig. 8). It is then possible to accept or reject an event with a time precision of about 30 ns and a delay defined by the electron drift-time. Together with S. Majewski we found a structure reaching this goal. It made it possible easily to amplify single photoelectrons released by an ultraviolet photon in a photosensitive gas. The drift region in fact largely eliminates the effect of the radiations emitted by excited atoms produced in an avalanche, which are responsible

for secondary effects by ejecting electrons near the initial position of the photoelectrons. We have built large detectors of this kind in collaboration with Saclay to obtain images of Cherenkov rings in an experiment performed at the Fermi Laboratory Tevatron in the United States. This development proved most fruitful, however, in a special biological field of application. There are several research fields in which it is necessary to obtain the image of the distribution of molecules marked with radioactive elements. Several commercial firms have tried to make use of wire chambers for this imaging purpose. The main difficulty lies in the generally considerable distance which the electrons from the radioactive bodies may have to travel in the gases. We have observed that an amplifying structure based on parallel grids did not suffer from this defect. Multiplying an electron by a Townsend avalanche, in fact, exponentially helps the ionization electrons released in the gas near the cathode, which is the entry window. Precisions of the order of 0.3 mm have thus been obtained for β radiation emitted by phosphorus-32, for instance.

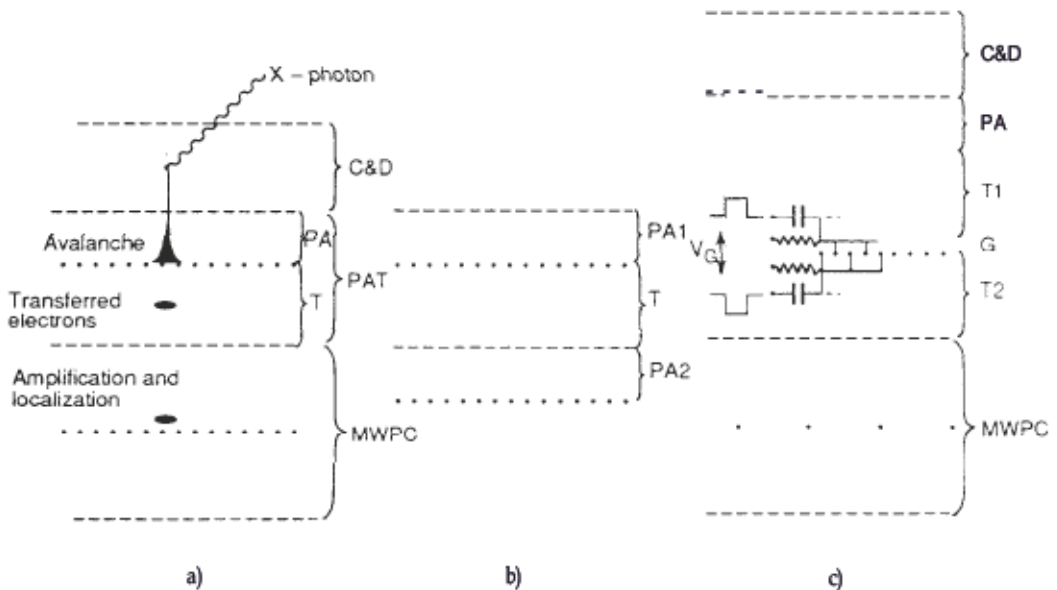

Fig. 8: Various multistage structures. (a) A preamplification (PA) and transfer (T) component is followed by a multiwire proportional chamber (MWPC); the conversion and drift space (C and D) makes it possible to inject a constant charge (X-rays etc.) into the amplification region. (b) Two parallel-plate units with charge transfer from PA1 to PA2. The best time resolutions were obtained with this configuration. (c) A multistage chamber with a gate: the wires of grid G are at alternating potentials of ± 70 V. The electrons are transmitted from component PA + T, to MWPC and they are transferred when the wires are brought to the same potential by short pulses of 30 ns, making it possible to select rare events in a high rate environment.

We then took another step by coupling such a multiplication region with a method of reading out the position of the avalanches, making use of the light emitted. We had developed this method in order to study very rare

phenomena such as double β decay or collisions between gas atoms and certain types of hidden matter. We thought that only the redundancy provided by photographic methods could characterize a rare event. A British group was also independently tackling this method for imaging Cherenkov photons. They, too, used the multistage chambers which we had introduced and reached the same conclusion: with suitable vapours it was possible to obtain a sufficiently plentiful emission of photons to detect the light emitted by the avalanches with simple optics.

The great advantage of this method lies in the read-out which it permits in the use of hundreds of thousands of channels now making up the CCD (charge-coupling device), which is the basic component of video cameras. Moreover, the fact that the image of a light avalanche covers several pixels makes it possible to interpolate the centre of the avalanche and multiply the number of real channels by almost 10. We were thus able to make an instrument for visualizing the distribution of the electrons emitted by tritium in a slice of rat's kidney, making it possible to observe details of about 100 μm . The fact that the same data (fig. 9) were obtained in a single day instead of the three months previously required by the photographic method aroused immediate interest among certain biologists and gave rise to a development which is still under way.

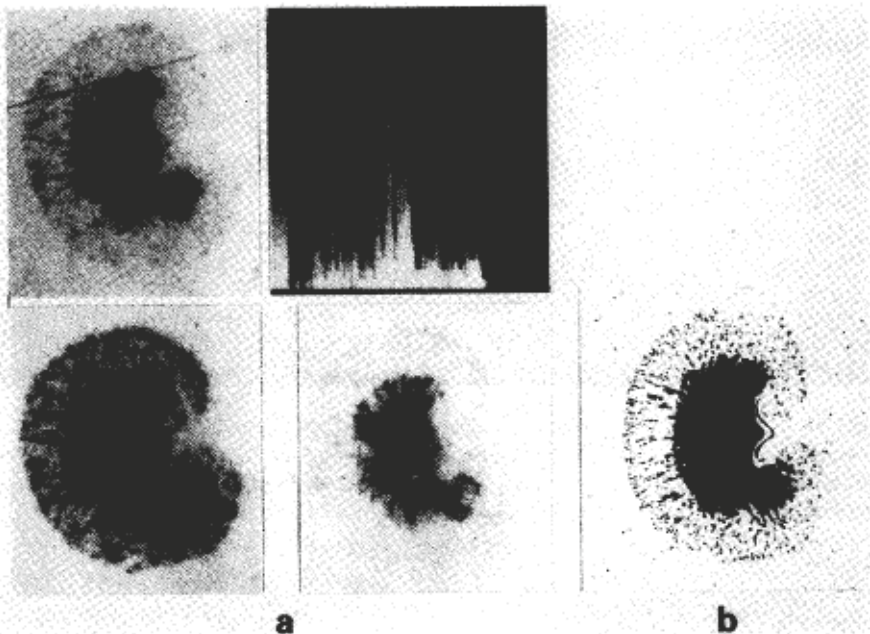

Fig. 9: Images of samples taken from a tritium-marked rat's kidney. The four parts of diagram (a) were obtained with a gas detector: the window, centred at three different levels, has a grey scale of 2.56. The intensity spectrum is taken along the oblique line marked on the first view with 40 μm pixels in the sample plane. The gas mixture is xenon with 2.5% triethylamine. The details of the renal channels, measuring 50 μm , can be seen. This image may be obtained in 20 hours. (b) Autoradiograph showing the adjacent slice of rat's kidney to which a photographic emulsion was applied for 3 months.

Our latest experiment with gas detectors comprising parallel-grid structures helped convince us that the controlled multiplication of avalanches in gases, in structures as diverse as wires or parallel surfaces, by selecting photocathodes compatible with gas amplification is still a source of fruitful developments: in many fields this multiplication may still result in progress in all fields where radiation must be imaged, from ultraviolet photons to γ -rays and the highest-energy particles. At the current stage of high-energy physics, however, simply making use of the location of free electrons near the wires of proportional chambers and the drift-time of the electrons provides an image of configurations rivalling in complexity those provided by bubble chambers. This is shown in fig. 10, the image of an event generated in the ALEPH detector installed at one of the intersections of LEP, the large e^+e^- collider operated at CERN.

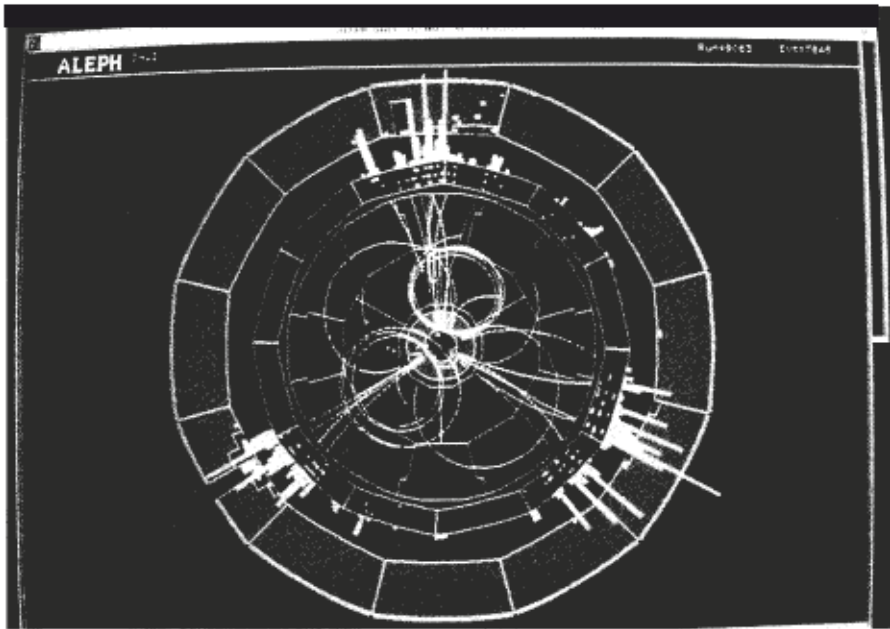

Fig. 10: Image of an e^+e^- collision obtained at the ALEPH experiment at LEP using an instrument making use of the drift-time in a large volume and the read-out of coordinates projected in a wire chamber. Auxiliary outside detectors provide the information on the energy of the particles, the trajectory of which was displayed.

BIBLIOGRAPHY

A very comprehensive historical study with most references corresponding to the period covered by this article is to be found in

I. Gambaro, The development of electron detectors at CERN (1966 - late 1970s), *CERN History Study No. CHS-39*, January 1992.

Our first article that described the properties of multiwire structures is

G. Charpak, R. Bouclier, T. Rressani, J. Favier and C. Zupancic, The use of multiwire proportional chambers to select and localize charged particles, *Nuclear Instruments and Methods* 62 (1968) 202 - 26.

It was followed by several articles, one of them giving a description of the progress we made during our first year of studies of the wire chambers and the drift chambers:

G. Charpak, D. Rahm and H. Steiner, Some developments in the operation of multiwire proportional chambers, *Nuclear Instruments and Methods* 80 (1970) 13 - 35.

We refer the reader to highly detailed works such as

F. Sauli, Principles of operation of multiwire proportional and drift chambers, *CERN 77-09* (1977).

P. Rice-Evans, *Spark, streamer, proportional and drift chambers* (Richelieu, London, 1974),

T. Ferbel, *Techniques and concepts of high-energy physics* (Plenum Press, New York, 1987),

and to a book giving a good analysis of the development of detectors in relation to the evolution of particle physics:

F. Close, M. Marten and C. Sutton, *The particle explosion* (Oxford University Press, 1987).