

# THE ORIGIN OF MACROMOLECULE IONIZATION BY LASER IRRADIATION

Nobel Lecture, December 8, 2002

by

KOICHI TANAKA

Shimadzu Corporation, 1 Nishinokyo-Kuwabaracho, Nakagyo-ku, Kyoto 604-8511, Japan.

## INTRODUCTION

When I was a student at university, my major field of study was Electrical Engineering. I did not specialize in chemistry in my studies at university, and my knowledge of chemistry overall was somewhat less than rich. Under those circumstances, upon entering the company, I applied myself wholeheartedly to the study of chemistry to challenge and overcome a barrier in analytical chemistry considered to be impenetrable. I am, of course, very pleased to receive the Nobel Prize and further, especially pleased that the Prize serves to acknowledge my efforts and successes in the field of analytical chemistry, a field that while rather inconspicuous among the general population is indeed very important and useful to the world.

I am employed by the analytical instrument manufacturer, Shimadzu Corporation. I was assigned to a team charged with the task of designing and building a completely new mass spectrometer. The achievement of developing “a soft desorption ionization method for mass spectrometric analysis of biological macromolecules”, for which I was chosen to receive this prize, was one aspect of that project. At that period in the 1980’s, four of my colleagues, whom I will introduce shortly, in addition to myself, were each in charge of developing a part of the instrument. I was responsible for developing the sample preparation and ionization technologies. Success of the instrument would not have been assured unless the other technologies were suitably provided, even given the excellence of the ionization technology. First, I will briefly describe the progress of development of the technologies at that time, other than that of ionization.

## MASS SEPARATION: TOF TECHNOLOGY

In mass spectrometry, it is necessary to use some method to separate the generated ions according to mass, and then perform detection of the ions. One of these methods is called *Time-of-Flight* Mass Spectrometry (TOF-MS), which involves separating ions according to mass by measuring their respective flight times.

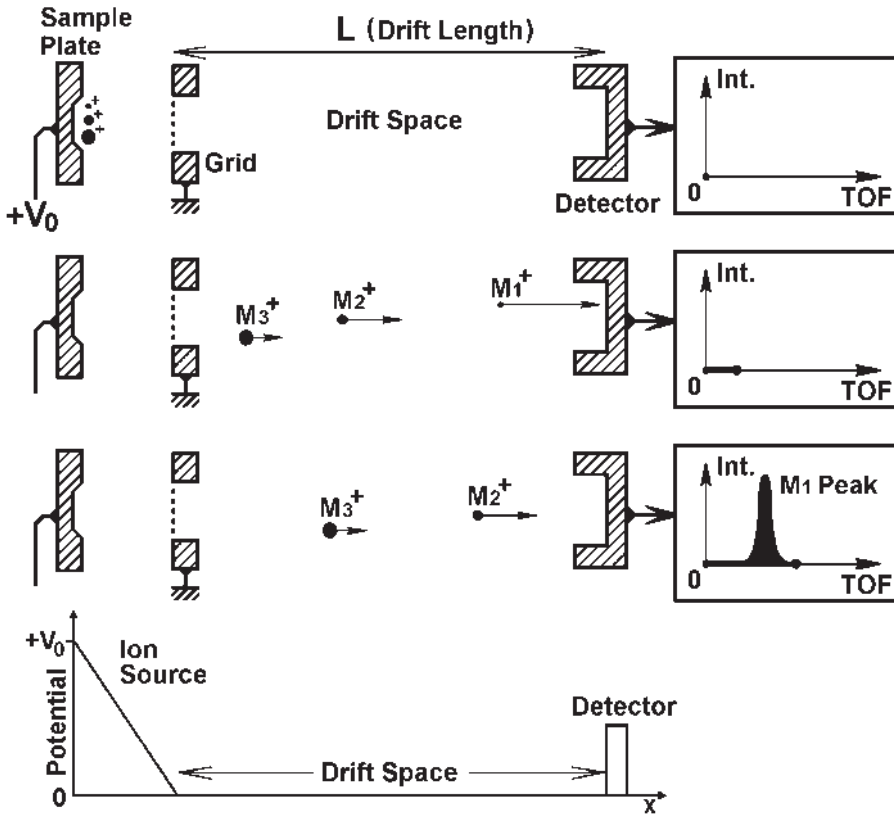

Figure 1. Schematic of Time of Flight Mass Spectrometry.

$$zV_0 = \frac{1}{2}mv^2$$

$$v = \sqrt{\frac{2zV_0}{m}} \quad \text{----- (1)}$$

$$t = \frac{L}{v} = L \cdot \sqrt{\frac{m}{2zV_0}} \quad \text{----- (2)}$$

$$t' = L \cdot \sqrt{\frac{m}{2(zV_0 + \epsilon)}} \quad \text{----- (2)'}$$

$z$ : charge of ion,  $m$ : mass of ion,  $v$ : velocity of ion,

$L$ : length of drift space,  $t$ : flight time of ion in drift space,

$t'$ : flight time of ion in drift space with initial kinetic energy  $\epsilon$

Figure 1 provides the simplest representation of the principle behind TOF-MS. This assumes that equally charged ions of differing mass,  $M_1$ ,  $M_2$  and  $M_3$  are generated instantly at the same time and starting position. Assume that  $M_1$  is the lightest of the ions. The ions are generated at an electrical potential

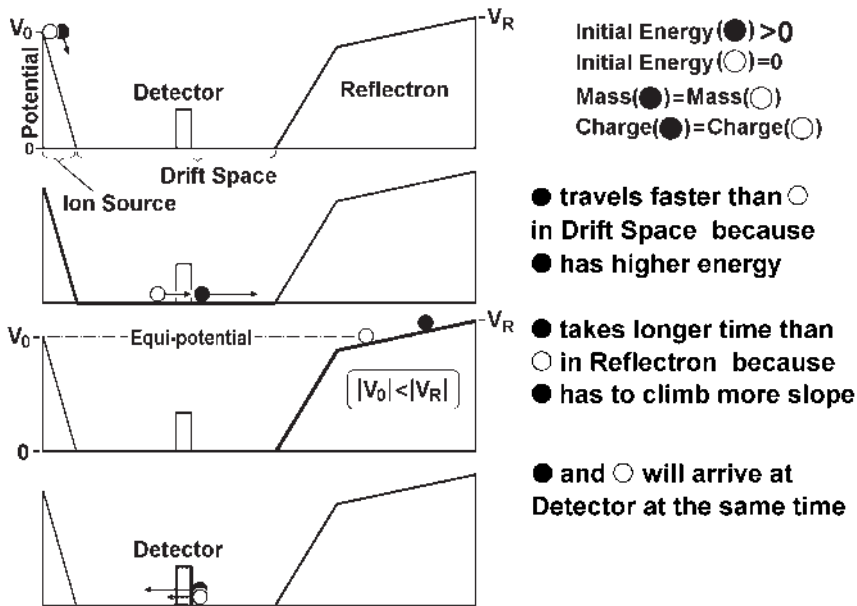

Figure 2. Mass Resolution Improvement by Reflectron.

$V_0$ , and have a potential energy of  $zV_0$ , where  $z$  is the charge of the ion. If all of the potential energy is converted to kinetic energy, the velocity  $v$  is expressed by Equation (1), based on the law of conservation of energy. In other words, the lighter ion travels at a higher speed, reaching the detector first.

This explanation is based on ideal conditions (Equation (2)). Since the ions actually possess a distribution of initial velocities, that is, initial kinetic energy  $\epsilon$ , their arrival time  $t'$  at the detector will show some distribution, even among ions of equal mass (Equation (2)'). This results in diminished mass resolution.

## REFLECTRON TECHNOLOGY

To improve the resolution, it would be best if ions of the same mass and charge arrive at the detector at the same time, even if their initial kinetic energies are different. Specifically, a device referred to as a *Reflectron*, first described by Boris Mamyryn<sup>[1]</sup> in 1973, is used to reflect the ions midway in their flight back toward the detector. This turning back of the ions has the effect of adjusting the flight times of the ions in conjunction with their initial kinetic energies, to ensure that ions of the same mass and charge reach the detector at the same time (Figure 2).

The isochronism of the pendulum is very well known. Stated simply, even if the swing amplitude of the pendulum varies, the cycle times remain equal as long as the cord length of the pendulum and the force of gravity stay the same. Applying this principle, an ideal Reflectron was developed. In this case, the cord length corresponds to the ion mass, the swing amplitude to the initial kinetic and potential energy, and the cycle time to the time of flight, re-

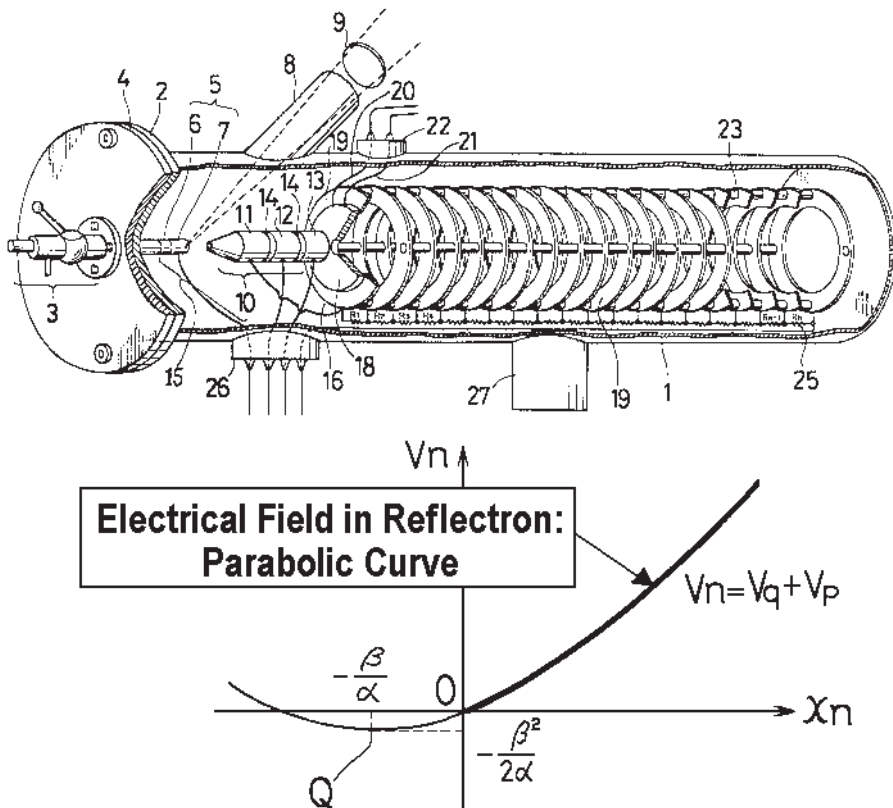

Figure 3. Mass Resolution Improvement by Ideal Reflectron (Patent: US4625112).

spectively. One method of this Reflectron technology was developed by one of my colleagues at that time, Mr. Yoshikazu Yoshida (Patent number: US4625112 issued in 1986) (Figure 3).

#### TIME DELAYED ION EXTRACTION

The principle behind TOF-MS assumes that ions are generated instantaneously, that is, in an infinitely short generation time. The time width of a laser pulse is extremely small, in the order of a few nanoseconds in the case of the  $N_2$  laser. However, when the laser intensity is high enough to greatly exceed the ion generation threshold, as shown in Figure 4, ions may continue to be generated even after the completion of laser irradiation. In the TOF model, the mass resolution decreases due to the wider time width of ion generation.

One of my colleagues at that time, Dr. Tamio Yoshida, succeeded in improving the mass resolution, as shown in Figure 5, by drawing out the time from ion generation to ion extraction. This is accomplished by maintaining equivalent voltages at the sample plate and the grid to prevent the ions from being extracted until they are all generated, and then by creating a potential

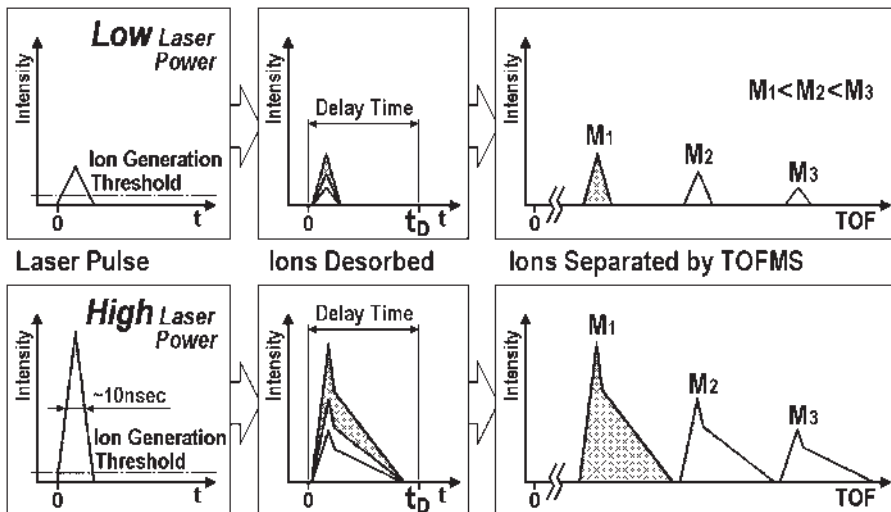

Figure 4. TOF Mass Spectrum Measurement with Low and High Laser Power.

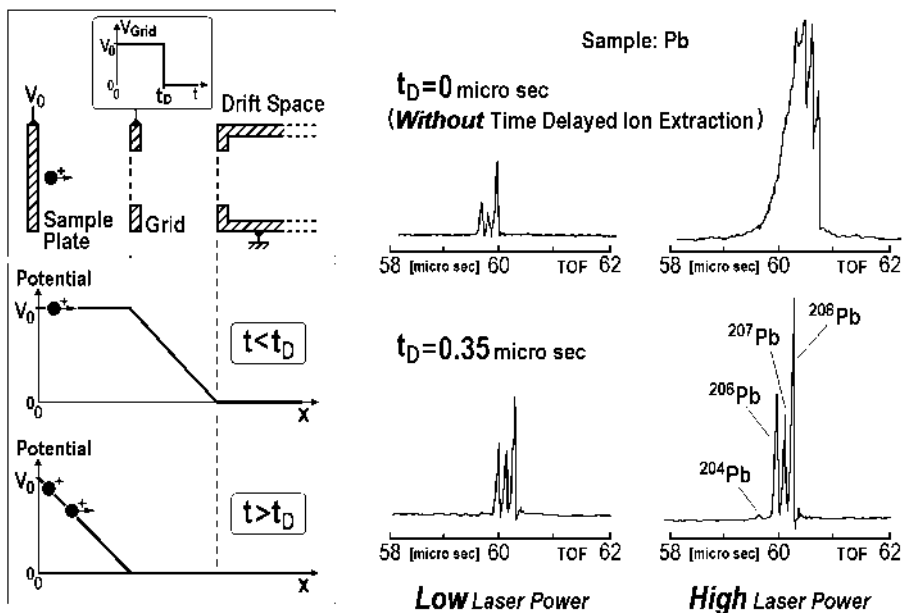

Figure 5. Mass Resolution Improvement by Time Delayed Ion Extraction.

difference after  $t_D$  to cause extraction of all the ions at the same time (filed in Japan Patent Office [S60035097] in 1985). This method is the same in principle as the *time-lag focusing* method which was originally designed by William Wiley and Ian McLaren<sup>[2]</sup> to reduce the effect of initial spatial and kinetic energy distributions, but was now applied specifically to minimize the effect of the prolonged laser-induced ion generation time.

In addition, there is a heightened possibility that particles given a charge,

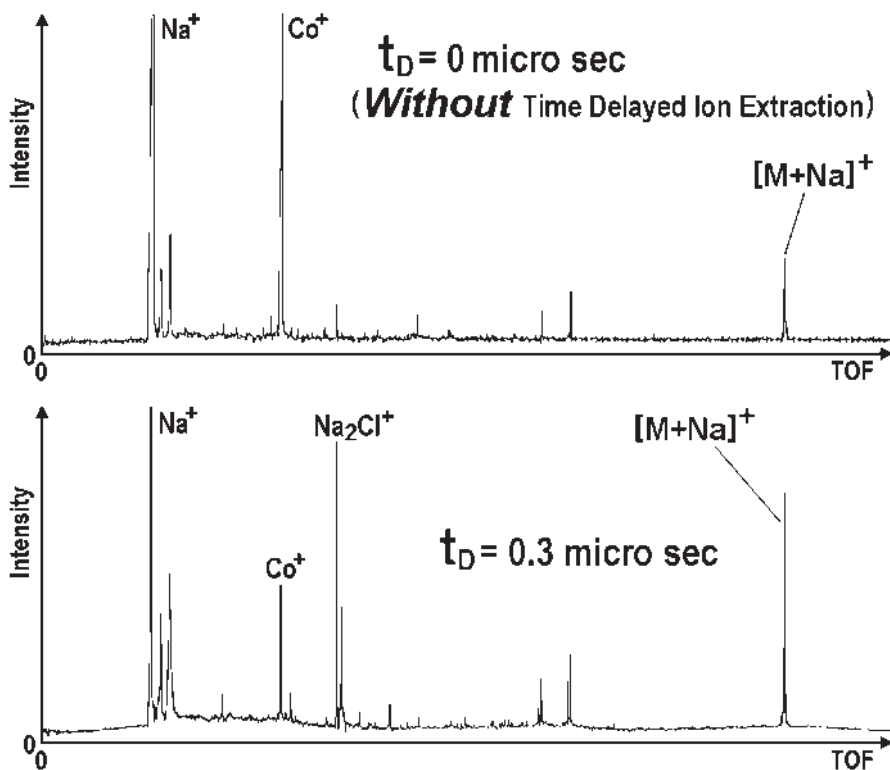

Figure 6. Molecular Ion Increase by Time Delayed Ion Extraction.

for example, protons and cations, will collide and react with normally neutral, that is, uncharged sample molecules. Such processes are generally referred to as *chemical ionization*, as originally described by Burnaby Munson and Frank Field.<sup>[3]</sup> The quantity of molecular ions ( $[\text{M}+\text{Na}]^+$  in Figure 6) can be expected to increase.

## ION DETECTION TECHNOLOGY

The term “detector” here refers to the conversion of ions separated by the mass separation mechanism into a flow of electrons, in other words, an electrical signal. The maximum mass number of ions that had been detected in the early 1980’s was in the range of several thousand. In principle, the greater the molecular weight (M.W.) of the ion, the slower the velocity, so the ion-to-electron conversion efficiency could even drop to zero.

The simplest method of raising sensitivity is to accelerate the ions even further after mass separation occurs (this is called *post acceleration*). As shown in Figure 7, the higher the post acceleration voltage, the greater the intensity of the ions, and further, the higher the mass number, the greater will be the effect, especially when a high voltage is applied. Another method is the ion-to-

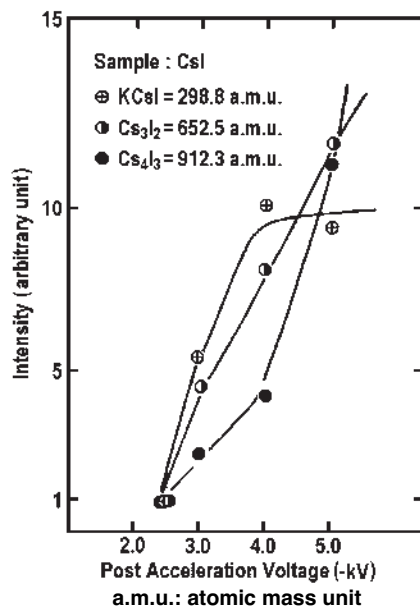

Figure 7. High Sensitivity Ion Detection by Post Acceleration.

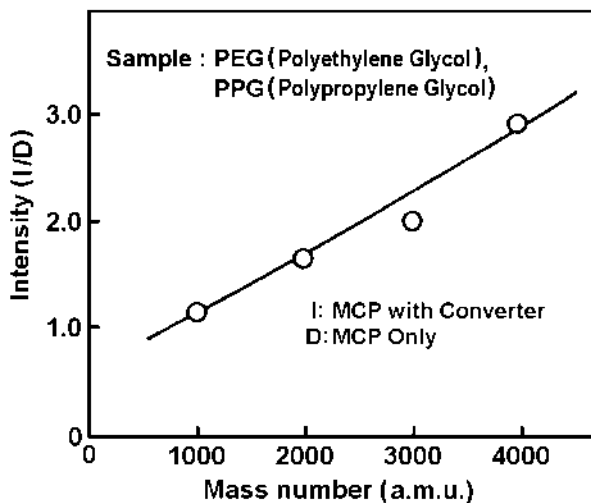

Figure 8. High Sensitivity Ion Detection by Ion-to-Electron Conversion.

electron conversion method. As shown in Figure 8, the intensity increases using this method as well.

One of my colleagues at that time, Mr. Yutaka Ido, developed a detector (Figure 9) that obtained the effects of both of these methods, enabling sufficiently sensitive detection even when ions of especially high molecular weight were generated.

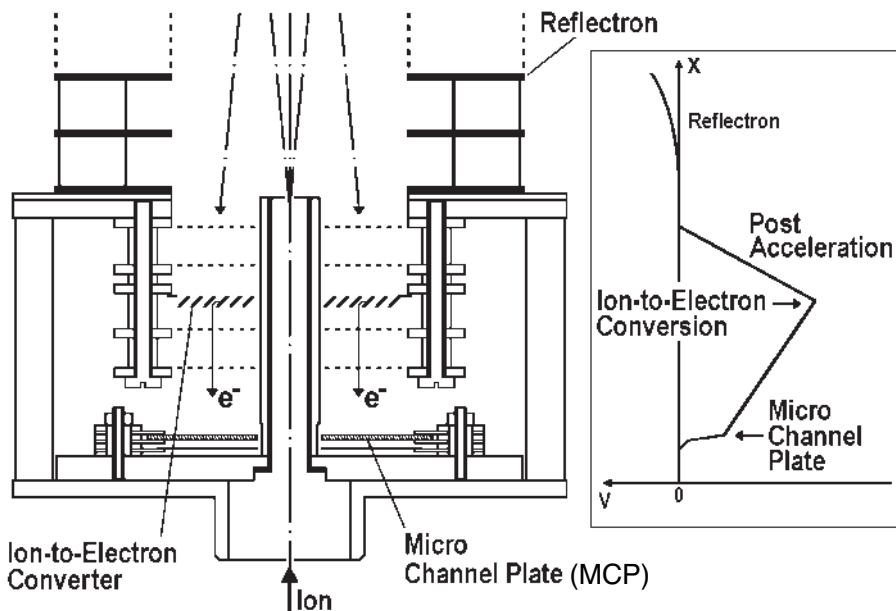

Figure 9. Macromolecule Detection by Post Acceleration and Ion-to-Electron Conversion.

## MEASUREMENT TECHNOLOGY

### ADC method

Even with improved detector sensitivity, it can be assumed that the intensity of macromolecular ions would be weak. In particular, when performing a single, one-shot measurement using a minute quantity of sample, successful quantitative analysis may not be possible without a high enough signal-to-noise (S/N) ratio. For this reason, a spectrum accumulation circuit is considered to be indispensable. To satisfy the demand for an instrument capable of high-speed measurement, a TOF spectrum measurement accumulation circuit was developed within our group.

One of my colleagues at that time, Mr. Satoshi Akita, developed an analog-to-digital converter (ADC) circuit adopting a *pipeline technique* to achieve the required speedup in measurement. The newly developed ADC circuit provided a maximum 1 kHz processing speed with real-time accumulation measurement at a maximum time resolution of 10 nsec and 24 bit intensity resolution (Figure 10).

Moreover, to enable measurement of both low mass high intensity ions as well as high mass low intensity ions, an amplifier that could perform gain switching within one microsecond was developed and adopted to provide a wider dynamic range.

### TDC Method

At that time, ADC circuits had a time resolution of 10 nsec. It was our opinion that even this resolution would not be enough. Mr. Yoshikazu Yoshida devel-



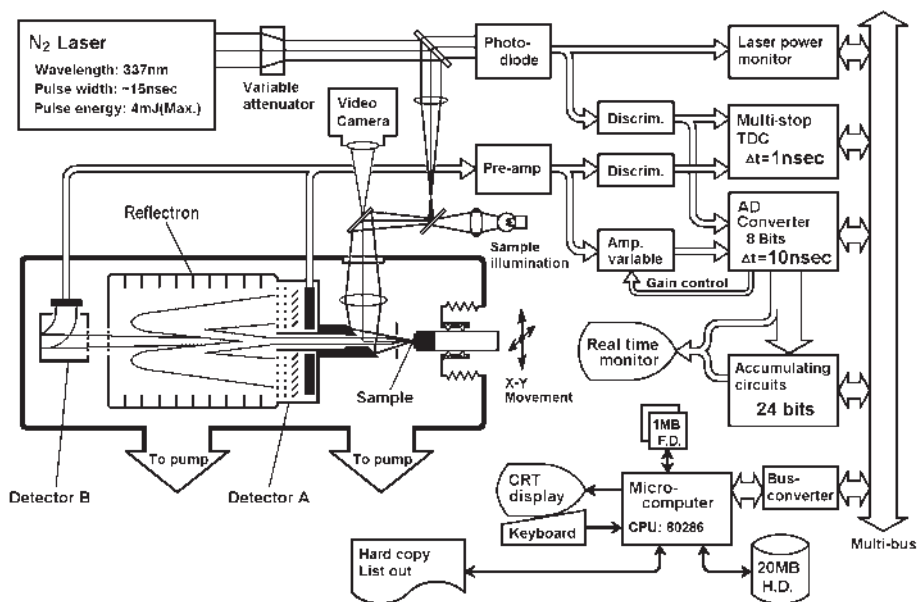

Figure 10. Schematic of Shimadzu LDI-TOFMS.

oped a time-to-digital converter (TDC) circuit that could measure with great accuracy the flight time of the ions while measuring a maximum of 255 events after one start signal (Multi-Stop-TDC), even though peak intensity information was sacrificed. As a result, we were able to measure the time of flight at a maximum time resolution of 1 nsec (Figure 10).

All of these crucial developments further emphasize the certainty that if even one of our group of five were not there, we would not have been able to achieve measurement of macromolecular ions. I am truly happy that the technologies we developed in the 1980's have been improved through their use in various instruments, and that they have played a role in bringing TOF technology into the mainstream of MS from the 1990's.

## IONIZATION TECHNOLOGY

Long before the 1980's, there had been investigation into the use of optical energy, not limited to laser light, to achieve ionization of organic compounds.<sup>[4]</sup> However, for the most part, this ionization consisted of stripping electrons from compounds in the gas phase.<sup>[5]</sup> Because this was limited to compounds that could be vaporized without being decomposed, very few compounds could be ionized. When a solid phase organic compound was irradiated with a laser, the organic compound absorbed the laser light, providing enough energy for desorption. Further, when the positive and negative charges of the particle are not in balance, it could be measured as an ion. However, in this case, since the laser light is absorbed directly into the analyte,

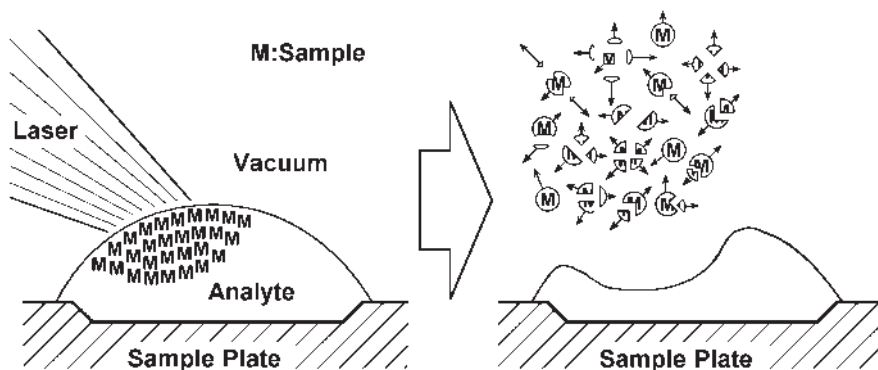

Figure 11. Laser Desorption Ionization (LDI) from Solid or Liquid Phase.

the molecular bonds may be broken due to the increased internal energy. In other words, there is an increased risk that measurement would occur in the decomposed state (Figure 11). Because we wanted to measure the un-decomposed, intact molecular ion, this was unsatisfactory.

At that time, the molecular weight of compounds that could be ionized by laser was about 1,000 Da, and ionization of compounds having a molecular weight exceeding 10,000 Da was generally considered by chemists at the time to be impossible. However, not being a specialist in chemistry, I was unaware of the existence of this widely-held belief.

## RAPID HEATING TECHNOLOGY

In the 1980's, "desorption to gas phase by rapid heating" gained attention through the efforts of several groups that had obtained some degree of encouraging results. These include Franz Röllgen<sup>[6, 7]</sup> of Germany, Mamoru Ohashi<sup>[8]</sup> of Japan, and Louis Friedman<sup>[9]</sup>, Don Hunt<sup>[10]</sup>, Burnaby Munson<sup>[11]</sup> and Robert Cotter<sup>[12]</sup> of the USA. A simple description of the principle is depicted in Figure 12. In short, if a given compound "AB" is heated, it is assumed that "AB" will be released to the gas phase as intact "AB" as well as fragmented "A" and "B". Respectively applying the well-known Arrhenius Equation (Equation (3)) will give the logarithmic expressions shown in Equation (4).

Here, for compounds that are thermally labile and decompose easily, the rate constant for decomposition " $K_D$ " is larger than that for vaporization " $K_V$ " at low temperatures. Because the activation energy for vaporization " $E_V$ " is higher than that for decomposition " $E_D$ ", the slope of the vaporization reaction " $K_V$ " in Figure 12 is steeper than that of the decomposition reaction.

If this is always correct, at high temperature, where  $1/T$  is small, vaporization should be further promoted. In other words, reaching the highest possible temperature as quickly as possible should provide a high degree of vaporization.

## USE OF UFMP

To perform this rapid heating, various heating methods were devised.<sup>[9]</sup> However, a high enough temperature could not be achieved quickly enough to obtain intact vaporization of macromolecules, such as proteins. Since the time width of a pulse laser itself is between a nanosecond to several microseconds, rapid heating would seem possible using a focused beam to generate energy at high density and high speed. However, this would require a medium to enable its conversion into thermal energy.

In Japan at that time in the 1980's, *Ultra Fine Metal Powder* (UFMP) received much attention in the field of metallurgy due to its usefulness in efficient production of alloys, and was referred to as *Japanese Powder*. UFMP, as its name indicates, is an extremely fine metallic powder with particle diameters measuring a few tens of nanometers. When compared to bulk metal, the particle diameter of UFMP is about the same as a wavelength, increasing the possibility that scattered light could be taken up internally (Figure 13). In other words, light energy could be absorbed more efficiently. Even visually, it is black in color. Moreover, the possibility that thermal energy would be dispersed and lost decreases due to the inter-particle spaces.



$$\text{Arrhenius Equation: } K = F \exp(-E/RT) \text{ ----- (3)}$$

K: Rate constant    F: Frequency factor    E: Activation energy  
R: Gas constant    T: Absolute temperature

$$\ln K_V = \ln F_V - E_V/RT, \quad \ln K_D = \ln F_D - E_D/RT \text{ ----- (4)}$$

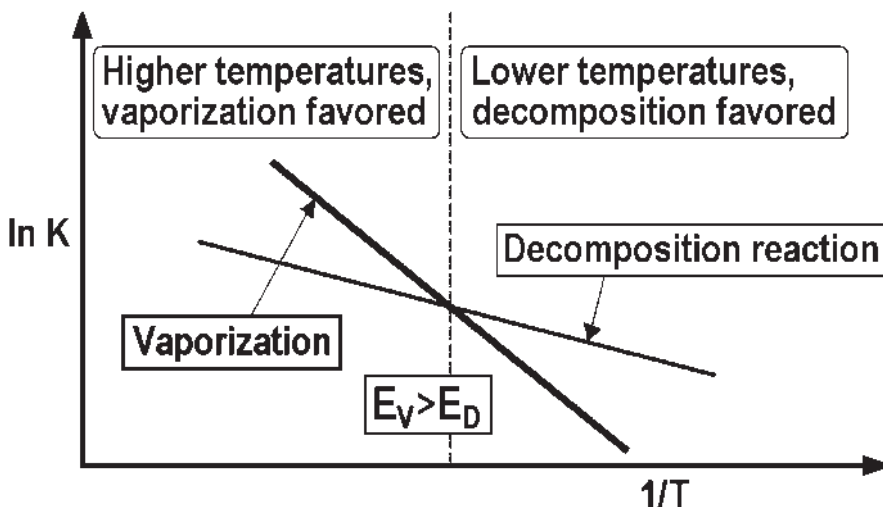

Figure 12. Vaporization vs. Decomposition.<sup>[9]</sup>

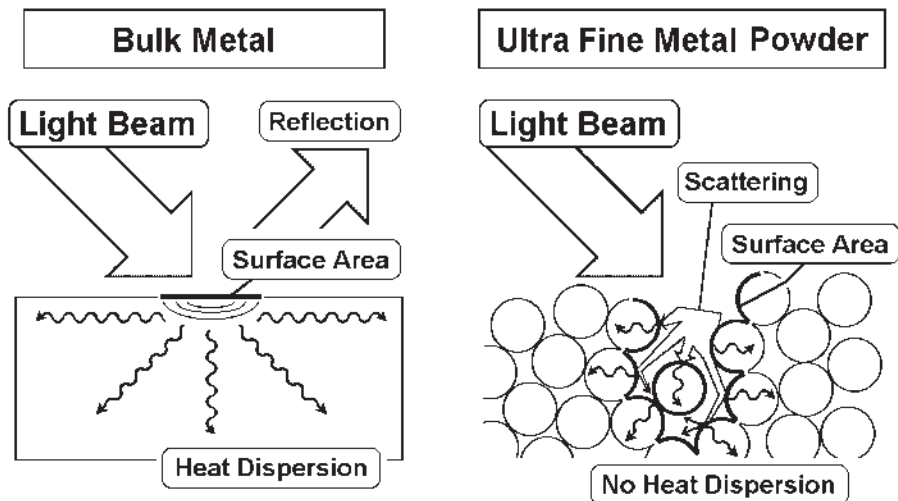

Figure 13. Differences between Bulk Metal and Ultra Fine Metal Powder.

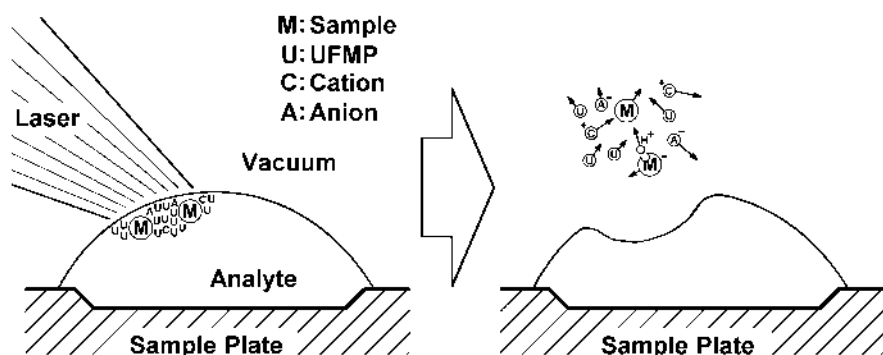

Figure 14. Molecular Ion Desorption by using UFMP Matrix.

Mixing this with an organic compound should allow the laser light to be efficiently absorbed into the UFMP, and to achieve a high UFMP temperature very quickly without the dispersion and loss of heat. This would efficiently achieve heating of the sample in the mixture. It was Mr. Yoshikazu Yoshida who proposed using UFMP as a *matrix*\* (Figure 14) (filed in 1985, Patent number: JP01731501 issued in 1993).

There was at that time an interest in using laser desorption for the analysis of polymers, such as in the reports by Charles Wilkins<sup>[13]</sup> of the USA. The MS spectrum shown in the upper part of Figure 15 is obtained when the sample, consisting of a polymer mixture of polyethylene glycols (PEG), is irradiated with a laser. The lower spectrum of Figure 15 shows that of the sample mixed with UFMP. With PEG alone, fragment ion peaks of the PEG molecule are dominant, and no PEG2000 peaks are observed. On the other hand, not on-

\* In the ionization method, a substance used to assist ionization is called a "matrix."

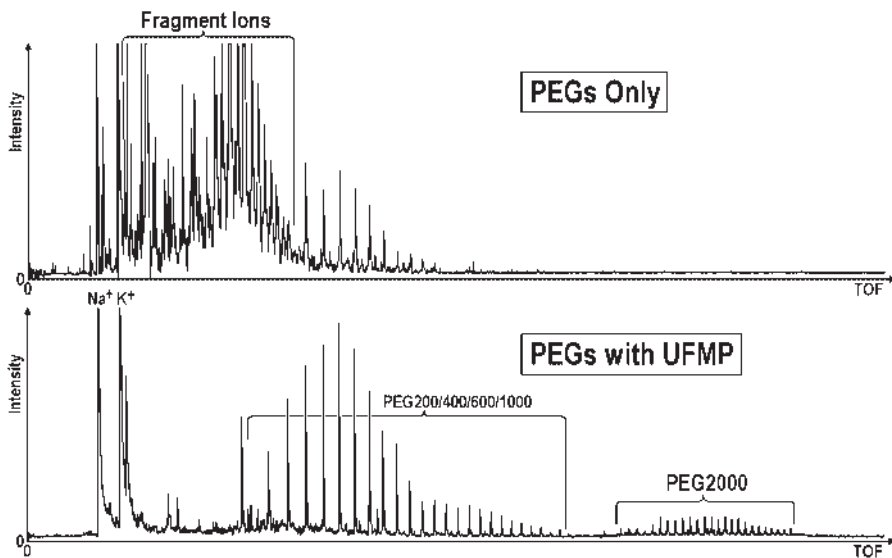

Figure 15. Polyethylene Glycols Spectra with and without UFMP Matrix.

ly are there almost no fragment peaks observed when PEG is mixed with UFMP, PEG2000 peaks have become clearly evident.

With the use of this matrix, the molecular ions from many organic compounds that could not be measured previously could then be measured. However, this technique could not be applied to compounds with molecular weights in the tens of thousands according to our experimental results.

## GLYCERIN MATRIX TECHNOLOGY

At that time in the 1980's, the *Fast Atom Bombardment* (FAB) MS method was widely used to achieve ionization in thermally labile compounds. The FAB method was developed by Michael Barber and colleagues<sup>[14]</sup>, and David

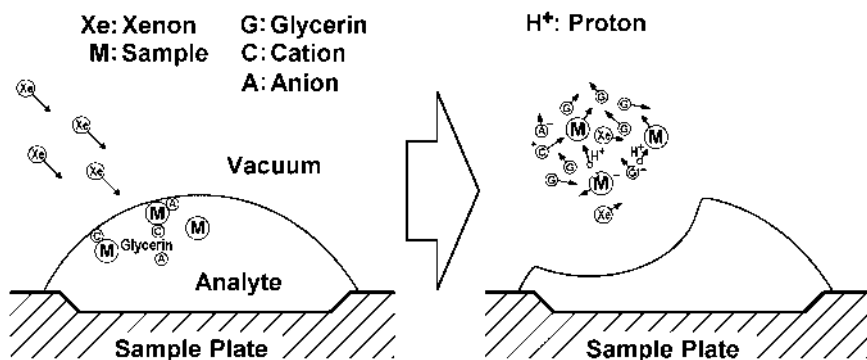

Figure 16. Molecule Desorption/Ionization using Glycerin Matrix in FABMS.

Surman and John Vickerman<sup>[15]</sup> of the UK, and involved accelerating neutral particles such as Xenon at high speed so as to collide with the sample and generate ions. In this method, the solid sample was maintained in a liquid state by using glycerin (glycerol) as a matrix (Figure 16).

It is thought that since glycerin is a liquid at room temperature, it releases the solid sample from its crystalline state to dissolve in the liquid, thereby assisting ionization. We used glycerin as a matrix just as it was used in FAB, but because the 337 nm laser wavelength that we used was only slightly absorbed into the glycerin, no significant effect was seen on the enhancement of molecular ion generation in organic compounds. However, this matrix was useful in improving reproducibility due to its effectiveness in providing a uniform mixture.

#### UFMP GLYCERIN MIXTURE TECHNOLOGY

Here it can be said that I had come up against a brick wall. Soon after that, while preparing many trial and error UFMP suspensions, changing the organic solvent and concentration repeatedly to obtain even the slightest improvement in data, I committed a monumental blunder, which was followed by a series of fortuitous, arbitrary decisions. I was using ordinary acetone as a UFMP suspension, and one day, by mistake, (1) I used the glycerin instead of the acetone. Reasoning that it would be wasteful to discard the expensive UFMP, (2) I decided to use the “ruined” preparation as the matrix solution. Because glycerin gradually evaporates in a vacuum, I knew it would eventually disappear. However, instead of waiting, (3) I decided to speed up vaporization of the glycerine by continuing to irradiate the laser. On top of that, because I wanted to see the result as soon as possible, (4) I was monitoring the acquisition of the TOF spectrum. In this way, only after at least four factors fell into place could I observe a phenomenon never before seen.

I think that the sample first measured was Vitamin B<sub>12</sub>. I have tried recently to locate the original spectrum, but unfortunately I couldn't find it. Because this sample itself can absorb laser light with an extremely high degree of efficiency, up to then, only the fragments could be measured with high sensitivity. However, by using the mixed UFMP glycerin matrix, at the position where unfragmented ions (molecular ions) should have appeared, peaks which seemed to be noise were observed. No matter how many times I performed the measurement, these peaks were present. Molecular ions were observed even after changing the sample.

After that, as a result of progressing to higher mass ions while optimizing the concentration, laser power and other parameters, I was able to measure an ion having a molecular weight of 35,000 Da (Figure 17) (1985) and another ion having a mass number exceeding 100,000 (Figure 18) (1987). The patent application for this ionization method was submitted in Japan in 1985, and was subsequently issued in 1993 (Patent number: JP01769145).

## WHY DID THE MACROMOLECULE BECOME IONIZED WITHOUT DECOMPOSING?

Use of UFMP conveniently allows high temperatures to be reached at high speed. However, even if this is mixed with a typical organic compound, it is difficult to achieve sufficient mixing. Even when viewing the mixture in an electron microscope-generated photograph, the lack of uniformity is obvious (Figure 19, top). When glycerin is added to the mixture, however, the uniformity becomes evident (Figure 19, bottom). Moreover, glycerin may also serve to release the sample from its crystalline state. The ability to measure mole-

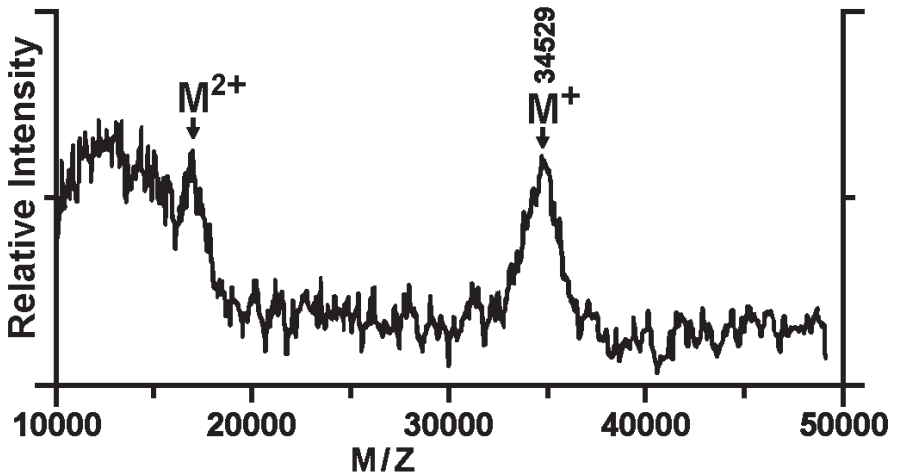

Figure 17. Molecular Ion Measurement of Carboxypeptidase-A (M.W.: ~35k Da).

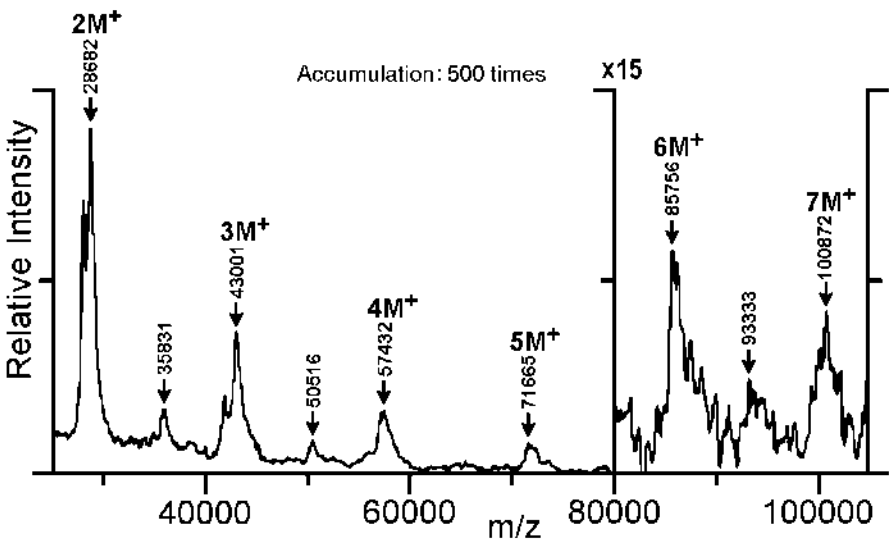
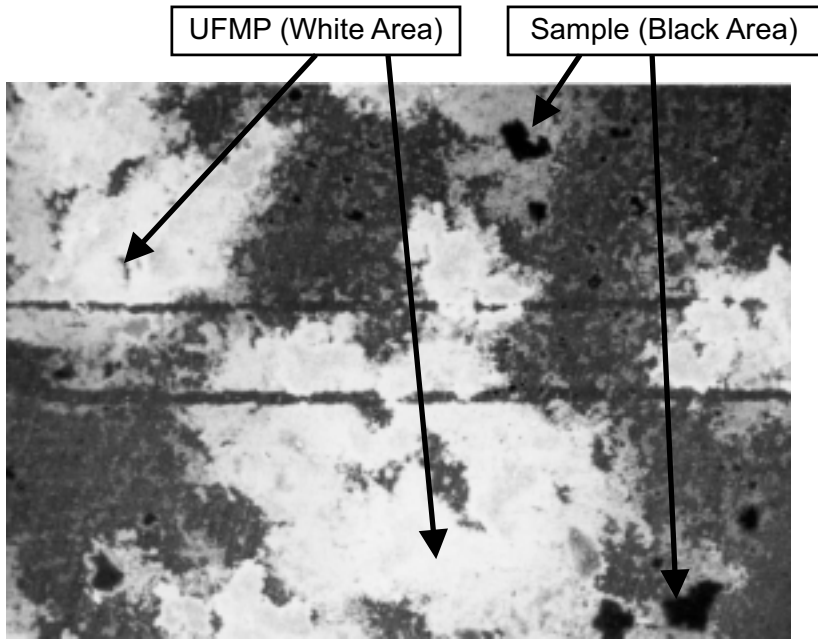
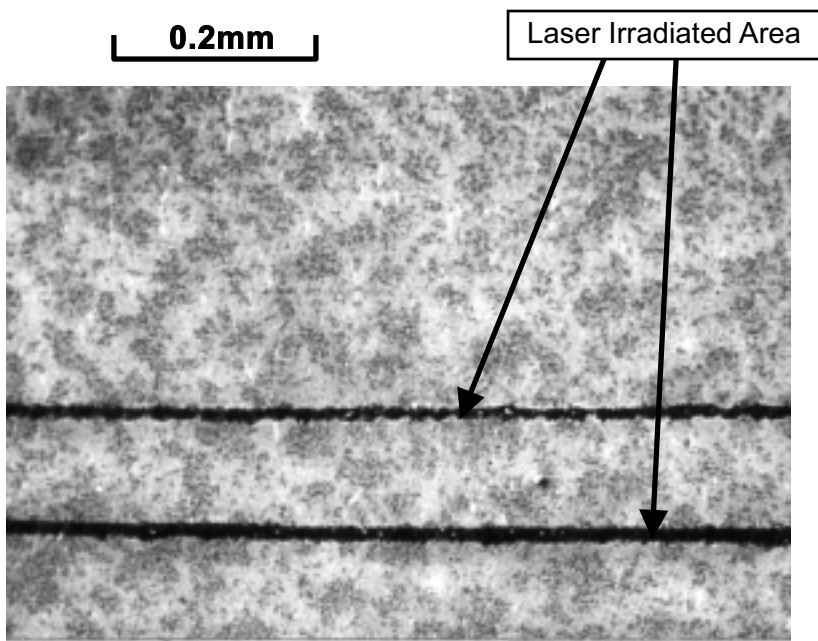

Figure 18. Cluster Ion Measurement of Lysozyme (M.W.: 14,306 Da).



Sample UFMP Mixture without using Glycerin

**0.2mm**



Sample UFMP Mixture with Glycerin

Figure 19. Electron Microscope Images of Sample and Matrix Mixture.



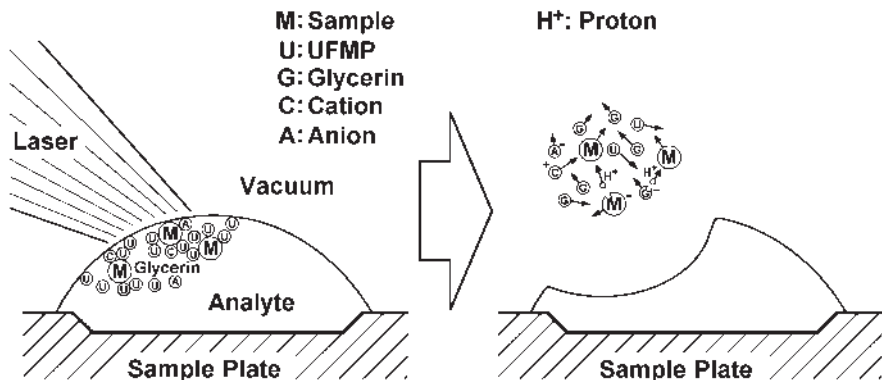

Figure 20. Macromolecule Desorption/Ionization using UFMP Glycerin Mixed Matrix.

cular ions from organic compounds even exceeding a molecular weight of 10,000 Da may indeed be due to these effects (Figure 20).

Here I have suggested the principles by which laser light irradiation is able to generate huge molecular ions. However, these principles are not necessarily correct because they have not yet been fully proven scientifically. Even with the knowledge of all the developments in *MALDI* (Matrix Assisted Laser Desorption / Ionization) technology that followed my discovery, I cannot yet claim to have correctly grasped the theoretical principles behind all of these phenomena.

However, I am an engineer, an engineer employed in a business enterprise. So even if the principles are unverified, their application takes priority if they are useful and practical.

## COMMERCIALIZATION AND PUBLIC ANNOUNCEMENT

If a business organization does not consider that a technology is basically saleable, development would not be advanced and there would be no announcement regarding the technology outside of the company. If this technology had not been made into a product, it would have been buried in-house and forgotten. For example, similar technology might have been developed somewhere else in the world in the 1980's, but if it had not been introduced to the international scientific community, it would not have been further developed to become a useful technique worldwide.

Because this basic technology that we developed at the Central Research Laboratory of Shimadzu Corporation was to be incorporated into a product, I was transferred to the business division. However, this technology was not made known outside the company until it was decided to release the product. The five members of our group made the first announcement outside the company at the Annual Conference of the Japan Mass Spectrometry Society held in Kyoto in May of 1987 (Oral and poster presentations <sup>[16-20]</sup> were conducted in Japanese). The announcement caused some reverberations, how-

ever, almost no one believed that this technology would become so useful. Of course, we were just pleased and satisfied to confirm that we had made scientific progress, and further, that we had presented it to the public.

## TECHNOLOGY TRANSFER TO EUROPE AND THE USA

In September of 1987, I participated in the Second Japan-China Joint Symposium on Mass Spectrometry that was held in Takarazuka, Japan, and presented the result for the first time in English.<sup>[21]</sup> At that time in the 1980's, *Plasma Desorption* MS (PDMS) was widely used as a method of measuring macromolecular compounds such as proteins.<sup>[22]</sup> During his presentation there, Professor Robert Cotter stated that "PDMS can measure higher masses than *Laser Desorption/Ionization* (LDI) MS." Professor Cotter was an authority with respect to TOF-MS even at that time, but given my own recent results, which I would present the next day, I could not agree with his statement. I apparently indicated to Professor Cotter that I thought he must be mistaken, and that he should look at my data. Professor Cotter tells me that he was indeed impressed with the high mass results. He later saw my poster presentation and he and Dr. Catherine Fenselau forwarded details of our ionization method and copies of the spectra to other researchers in Europe and the USA.

At that time, Dr. Takekiyo Matsuo, an assistant professor at Osaka University who was attending the symposium, strongly recommended that I write a formal paper in English. I reluctantly agreed, and in 1988, our contribution was published in *Rapid Communications in Mass Spectrometry* (RCM)<sup>[23]</sup>, and is referred to as one of the sources of the MALDI technique.

## MANUFACTURE AND THEN TERMINATION OF SALES

The analytical technology and the instrument became a commercial product. In order to sell the instrument, I traveled around Japan visiting many customers, and actually analyzed more than two hundred samples. However, the reaction was almost always, "There is little practical use." I then looked further afield and there was only one potential customer on whom we could pin our hopes. That was Dr. Terry D. Lee of the City of Hope's Beckman Research Institute in the USA. This became the first and only instrument of our commercialized product that was sold, and we eventually halted development and sales of the instrument. Although the instrument could do what no other instrument was capable of, it seemed to have little practical use. Perhaps, it is fair to say that the sensitivity, accuracy and resolution required improvement for use in pharmaceutical and medical diagnostic applications.

## DEVELOPMENT OF MALDI TECHNOLOGY AND ITS USE IN VARIOUS FIELDS

My research and development efforts on MALDI technology remained inactive until 1992 when I was transferred temporarily to KRATOS Analytical (a subsidiary company of Shimadzu Corporation from 1989) in Manchester, England. During that period, our technology that had been conveyed to Europe and the USA was steadily being improved upon and reformed through the efforts of Professor Cotter, Professor Fenselau and many other researchers throughout the world.

Special acknowledgement is also warranted for the meritorious efforts of both Professor Michael Karas and Professor Franz Hillenkamp<sup>[24-26]</sup> of Germany. Were it not for their tremendous and continuous efforts and the achievements of thousands of other researchers, it is certain that subsequent development of this technology that has benefited so many people around the world would not have advanced.

### CONCLUSION

Development of this Macromolecule Ionization technology was not accomplished by one genius or gifted person. It is a victory of teamwork, and I believe it is the result of a lot of honest activity by many individuals seeking to advance a good technology.

The history of chemistry is long and it is natural that the field is wide and deep. Because of this, there is a tendency to believe that chemistry-related technology is already well developed. It should be mentioned here that I strongly believe that building new theories and bringing them to useful roles in the world requires the total mobilization of knowledge in specialized fields. However, I think it can be said that the technique that I discovered and the subsequent technologies that originated throughout the world broke through the common knowledge of chemistry. If I had been caught within the grasp of this knowledge, I would not have been able to make this type of unique discovery. Even though I cannot claim to possess extraordinary intellectual abilities, and further, my academic specialization was in a field other than that of chemistry, there is enough proof that I was able to contribute to the development of chemistry-related technology. With this in mind, it would give me great pleasure if many people around the world, and especially engineers working in private business enterprises, would mobilize their courage and hold onto their dreams in the pursuit of scientific innovation for the benefit of all living beings.

### ACKNOWLEDGEMENT

I would like to express my thanks to Mr. Ralph Nesson for his tremendous efforts in helping me prepare for my Nobel Lecture presentation, and for his invaluable insight and patience in helping me express my thoughts in

English. I would also like to thank Prof. Robert Cotter, Prof. Catherine Fenselau, Dr. Chris Sutton and Dr. Andrew Bowdler for many stimulating discussions.

## REFERENCES

- [1] Mamyryn, B.A., Karataev, V.I., Shmikk, D.V., Zagulin, V.A. "The Mass-Reflectron, a New Nonmagnetic Time-of-Flight Mass Spectrometer with High Resolution" *Sov. Phys. JETP* Vol.37 No.1, pp.45–48 (1973).
- [2] Wiley, W.C., McLaren, I.H. "Time-of-Flight Mass Spectrometer with Improved Resolution" *Rev. Sci. Instr.* Vol.26 No.12, pp.1150–1157 (1955).
- [3] Munson, M.S.B., Field, F.H. "Chemical Ionization Mass Spectrometry. I. General Introduction" *J. Am. Chem. Soc.* Vol.88 No.12, pp.2621–2630 (1966).
- [4] Terrenin, A., Popov, B. "Photodissociation of Salt Molecules into Ions" *Physik Z. Sowjetunion* Vol.2, pp.299–318 (1932).
- [5] Lubman, D.M., Kronick, M.N. "Mass Spectrometry of Aromatic Molecules with Resonance-Enhanced Multiphoton Ionization" *Anal. Chem.* Vol.54 No.4, pp.660–665 (1982).
- [6] Giessmann, U., Röllgen, F.W. "Ion Formation by [Li]<sup>+</sup> Ion Attachment in High Electric Fields" *Org. Mass Spectrom.* Vol.11, pp.1094–1100 (1976).
- [7] Röllgen, F.W., Giessmann, U., Heinen, H.J., Reddy, S.J. "Field Ion Emitters for Field Desorption of Salts" *Int. J. Mass Spectrom. Ion Phys.* Vol.24, pp.235–238 (1977).
- [8] Ohashi, M., Yamada, S., Kudo, H., Nakayama, N. "In-beam Electron Impact Mass Spectrometry of Amino Sugars" *Biomed. Mass Spectrom.* Vol.5 No.10, pp.578–581 (1978).
- [9] Beuhler, R.J., Flanigan, E., Greene, L.J., Friedman, L. "Proton Transfer Mass Spectrometry of Peptides. A Rapid Heating Technique for Underivatized Peptides Containing Arginine" *J. Am. Chem. Soc.* Vol.96, pp.3990–3999 (1974).
- [10] Hunt, D.F., Shabanowitz, J., Botz, F.K., Brent, D.A. "Chemical Ionization Mass Spectrometry of Salts and Thermally Labile Organics with Field Desorption Emitters as Solids Probes" *Anal. Chem.* Vol.49 No.8, pp.1160–1163 (1977).
- [11] Hansen, G., Munson, B. "Surface Chemical Ionization Mass Spectrometry" *Anal. Chem.* Vol.50 No.8, pp.1130–1134 (1978).
- [12] Cotter, R.J., Fenselau, C. "The Effects of Heating Rate and Sample Size on the Direct Exposure/Chemical Ionization Mass Spectra of Some Biological Conjugates" *Biomed. Mass Spectrom.* Vol.6 No.7, pp.287–293 (1979).
- [13] Wilkins, C.L., Weil, D.A., Yang, C.L.C., Ijames, C.F. "High Mass Analysis by Laser Desorption Fourier Transform Mass Spectrometry" *Anal. Chem.* Vol.57 No.2, pp.520–524 (1985).
- [14] Barber, M., Bordori, R.S., Sedgwick, R.D., Tyler, A.N. "Fast Atom Bombardment of Solids (F.A.B.) : A New Ion Source for Mass Spectrometry" *J. Chem. Soc., Chem. Commun.*, pp.325–327 (1981).
- [15] Surman, D.J., Vickerman, J.C. "Fast Atom Bombardment Quadrupole Mass Spectrometry" *J. Chem. Soc., Chem. Commun.*, pp.324–325 (1981).
- [16] Yoshida, Y., Tanaka, K., Ido, Y., Akita, S., Yoshida, T. "Development of Laser Ionization Time of Flight Mass Spectrometer I — Curved Electric Field Ion Reflector"(in Japanese) *35-kai Shitsuryo Bunseki Rengo Toronkai, Yoshishu*, pp.12–13 (1987).
- [17] Akita, S., Tanaka, K., Ido, Y., Yoshida, Y., Yoshida, T. "Development of Laser Ionization Time of Flight Mass Spectrometer II — High-speed, High-accuracy Measuring Circuit for TOF Spectrum"(in Japanese) *35-kai Shitsuryo Bunseki Rengo Toronkai, Yoshishu*, pp.14–15 (1987).
- [18] Ido, Y., Tanaka, K., Akita, S., Yoshida, Y., Yoshida, T. "Development of Laser Ionization Time of Flight Mass Spectrometer III — Sensitive Ion Detection in High Mass Range"(in Japanese) *35-kai Shitsuryo Bunseki Rengo Toronkai, Yoshishu*, pp.20–21 (1987).

- [19] Tanaka, K., Ido Y., Akita, S., Yoshida, Y., Yoshida T. "Development of Laser Ionization Time of Flight Mass Spectrometer IV — Generation of Quasi-Molecular Ions from High Mass Organic Compound"(in Japanese) *35-kai Shitsuryo Bunseki Rengo Toronkai, Yoshishu*, pp.22–23 (1987).
- [20] Yoshida, T., Tanaka, K., Ido, Y., Akita, S., Yoshida, Y. "High Molecular Ion Detection using Laser Ionization TOF Mass Spectrometer"(in Japanese) *35-kai Shitsuryo Bunseki Rengo Toronkai, Yoshishu*, pp.30–31 (1987).
- [21] Tanaka, K., Ido, Y., Akita, S., Yoshida, Y., Yoshida, T. "Detection of High Mass Molecules by Laser Desorption Time-of-Flight Mass Spectrometry" *Proceedings of the Second Japan-China Joint Symposium on Mass Spectrometry*, pp.185–188 (1987)
- [22] Cotter, R.J. "Plasma Desorption Mass Spectrometry: Coming of Age" *Anal. Chem.* Vol.60 No.13, pp.781A–793A (1988).
- [23] Tanaka, K., Waki, H., Ido, Y., Akita, S., Yoshida, Y., Yoshida, T. "Protein and Polymer Analyses up to  $m/z$  100 000 by Laser Ionization Time-of-Flight Mass Spectrometry" *Rapid Commun. Mass Spectrom.* Vol.2 No.8, pp.151–153 (1988).
- [24] Karas, M., Bachmann, D., Hillenkamp, F. "Influence of the Wavelength in High-Irradiance Ultraviolet Laser Desorption Mass Spectrometry of Organic Molecules" *Anal. Chem.* Vol.57 No.14, pp.2935–2939 (1985).
- [25] Karas, M., Hillenkamp, F. "Laser Desorption Ionization of Proteins with Molecular Masses Exceeding 10 000 Daltons" *Anal. Chem.* Vol.60 No.20, pp.2299–2301 (1988).
- [26] Karas, M., Ingendoh, A, Bahr, U., Hillenkamp, F. "Ultraviolet-Laser Desorption/Ionization Mass Spectrometry of Femtomolar Amounts of Large Proteins" *Bio-med. Environ. Mass Spectrom.* Vol.18, pp.841–843 (1989).