

THE COSMIC MICROWAVE BACKGROUND RADIATION

Nobel Lecture, 8 December, 1978

by
ROBERT W. WILSON
Bell Laboratories
Holmdel, N.J. U.S.A.

1. INTRODUCTION

Radio Astronomy has added greatly to our understanding of the structure and dynamics of the universe. The cosmic microwave background radiation, considered a relic of the explosion at the beginning of the universe some 18 billion years ago, is one of the most powerful aids in determining these features of the universe. This paper is about the discovery of the cosmic microwave background radiation. It starts with a section on radio astronomical measuring techniques. This is followed by the history of the detection of the background radiation, its identification, and finally by a summary of our present knowledge of its properties.

II. RADIO ASTRONOMICAL METHODS

A radio telescope pointing at the sky receives radiation not only from space, but also from other sources including the ground, the earth's atmosphere, and the components of the radio telescope itself. The 20-foot horn-reflector antenna at Bell Laboratories (Fig. 1) which was used to discover the cosmic microwave background radiation was particularly suited to distinguish this weak, uniform radiation from other, much stronger sources. In order to understand this measurement it is necessary to discuss the design and operation of a radio telescope, especially its two major components, the antenna and the radiometer¹.

a. Antennas

An antenna collects radiation from a desired direction incident upon an area, called its collecting area, and focuses it on a receiver. An antenna is normally designed to maximize its response in the direction in which it is pointed and minimize its response in other directions.

The 20-foot horn-reflector shown in Fig. 1 was built by A. B. Crawford and his associate² in 1960 to be used with an ultra low-noise communications receiver for signals bounced from the Echo satellite. It consists of a large expanding waveguide, or horn, with an off-axis section parabolic reflector at the end. The focus of the paraboloid is located at the apex of the horn, so that a plane wave traveling along the axis of the paraboloid is focused into the receiver, or radiometer, at the apex of the horn. Its design emphasizes the rejection of radiation from the ground. It is easy to see

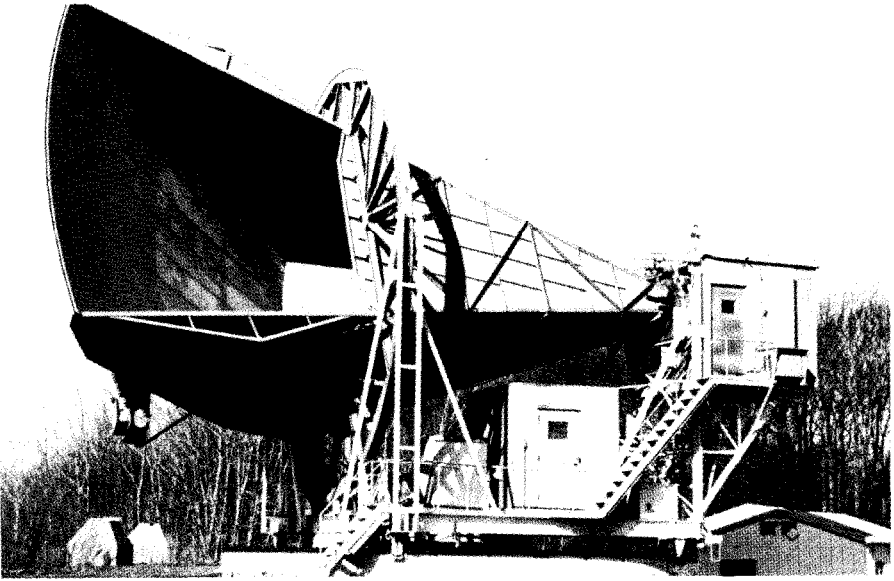

Fig. 1 The 20 foot horn-reflector which was used to discover the Cosmic Microwave Background Radiation.

from the figure that in this configuration the receiver is well shielded from the ground by the horn.

A measurement of the sensitivity of a small hornreflector antenna to radiation coming from different directions is shown in Fig. 2. The circle marked isotropic antenna is the sensitivity of a fictitious antenna which receives equally from all directions. If such an isotropic lossless antenna were put in an open field, half of the sensitivity would be to radiation from the earth and half from the sky. In the case of the hornreflector, sensitivity in the back or ground direction is less than $1/3000$ of the isotropic antenna. The isotropic antenna on a perfectly radiating earth at 300 K and with a cold sky at 0° K would pick up 300 K from the earth over half of its response and nothing over the other half, resulting in an equivalent antenna temperature of 150 K. The horn-reflector, in contrast, would pick up less than .05 K from the ground.

This sensitivity pattern is sufficient to determine the performance of an ideal, lossless antenna since such an antenna would contribute no radiation of its own. Just as a curved mirror can focus hot rays from the sun and burn a piece of paper without becoming hot itself, a radio telescope can focus the cold sky onto a radio receiver without adding radiation of its own.

h. Radiometers

A radiometer is a device for measuring the intensity of radiation. A microwave radiometer consists of a filter to select a desired band of

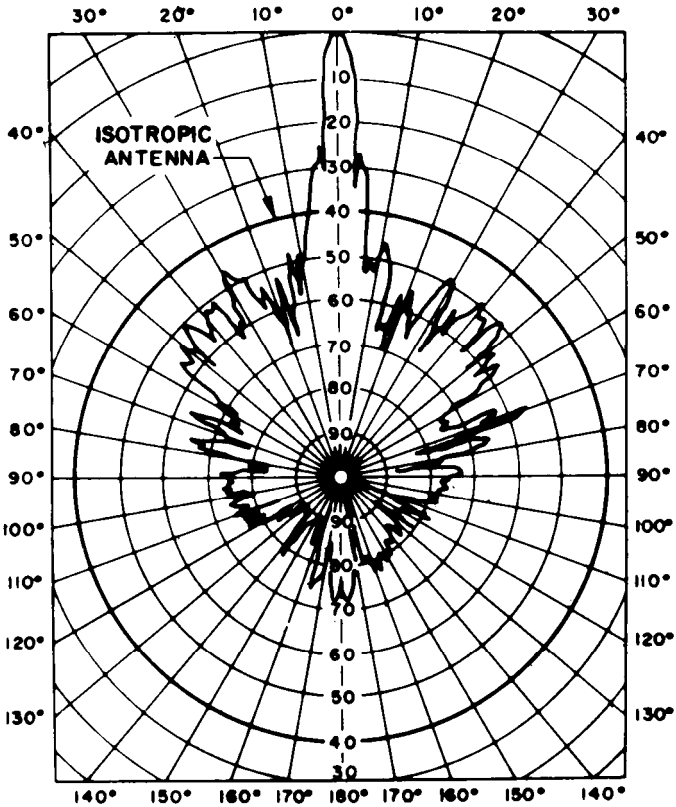

Fig. 2 Sensitivity pattern of a small horn-reflector antenna. This is a logarithmic plot of the collecting area of the antenna as a function of angle from the center of the main beam. Each circle below the level of the main beam represent a factor of ten reduction in sensitivity. In the back direction around 180 the sensitivity is consistently within the circle marked 70, corresponding to a factor of 10^7 below the sensitivity at 0.

frequencies followed by a detector which produces an output voltage proportional to its input power. Practical detectors are usually not sensitive enough for the low power levels received by radio telescopes, however, so amplification is normally used ahead of the detector to increase the signal level. The noise in the first stage of this amplifier combined with that from the transmission line which connects it to the antenna (input source) produce an output from the detector even with no input power from the antenna. A fundamental limit to the sensitivity of a radiometer is the fluctuation in the power level of this noise.

During the late 1950's, H. E. D. Scovil and his associates at Bell Laboratories, Murray Hill were building the world's lowest-noise microwave amplifiers, ruby travelling-wave masers³. These amplifiers were cooled to 4.2 K or less by liquid helium and contribute a correspondingly small amount of noise to the system. A radiometer incorporating these amplifiers can therefore be very sensitive.

Astronomical radio sources produce random, thermal noise very much

like that from a hot resistor, therefore the calibration of a radiometer is usually expressed in terms of a thermal system. Instead of giving the noise power which the radiometer receives from the antenna, we quote the temperature of a resistor which would deliver the same noise power to the radiometer. (Radiometers often contain calibration noise sources consisting of a resistor at a known temperature.) This "equivalent noise temperature" is proportional to received power for all except the shorter wavelength measurements, which will be discussed later.

c. Observations

To measure the intensity of an extraterrestrial radio source with a radio telescope, one must distinguish the source from local noise sources - noise from the radiometer, noise from the ground, noise from the earth's atmosphere, and noise from the structure of the antenna itself. This distinction is normally made by pointing the antenna alternately to the source of interest and then to a background region nearby. The difference in response of the radiometer to these two regions is measured, thus subtracting out the local noise. To determine the absolute intensity of an astronomical radio source, it is necessary to calibrate the antenna and radiometer or, as usually done, to observe a calibration source of known intensity.

III. PLANS FOR RADIO ASTRONOMY WITH THE 20-FOOT HORN-REFLECTOR

In 1963, when the 20-foot horn-reflector was no longer needed for satellite work, Arno Penzias and I started preparing it for use in radio astronomy. One might ask why we were interested in starting our radio astronomy careers at Bell Labs using an antenna with a collecting area of only 25 square meters when much larger radio telescopes were available elsewhere. Indeed, we were delighted to have the 20-foot horn-reflector because it had special features that we hoped to exploit. Its sensitivity, or collecting area, could be accurately calculated and in addition it could be measured using a transmitter located less than 1 km away. With this data, it could be used with a calibrated radiometer to make primary measurements of the intensities of several extraterrestrial radio sources. These sources could then be used as secondary standards by other observatories. In addition, we would be able to understand all sources of antenna noise, for example the amount of radiation received from the earth, so that background regions could be measured absolutely. Traveling-wave maser amplifiers were available for use with the 20-foot horn-reflector, which meant that for large diameter sources (those subtending angles larger than the antenna beamwidth), this would be the world's most sensitive radio telescope.

My interest in the background measuring ability of the 20-foot horn-reflector resulted from my doctoral thesis work with J. G. Bolton at

Caltech. We made a map of the 31 cm radiation from the Milky Way and studied the discrete sources and the diffuse gas within it. In mapping the Milky Way we pointed the antenna to the west side of it and used the earth's rotation to scan the antenna across it. This kept constant all the local noise, including radiation that the antenna picked up from the earth. I used the regions on either side of the Milky Way (where the brightness was constant) as the zero reference. Since we are inside the Galaxy, it is impossible to point completely away from it. Our mapping plan was adequate for that project, but the unknown zero level was not very satisfying. Previous low frequency measurements had indicated that there is a large, radio-emitting halo around our galaxy which I could not measure by that technique. The 20-foot horn-reflector, however, was an ideal instrument for measuring this weak halo radiation at shorter wavelengths. One of my intentions when I came to Bell Labs was to make such a measurement.

In 1963, a maser at 7.35 cm wavelength³ was installed on the 20-foot horn-reflector. Before we could begin doing astronomical measurements, however, we had to do two things: 1) build a good radiometer incorporating the 7.35 cm maser amplifier, and; 2) finish the accurate measurement of the collecting-area (sensitivity) of the 20-foot horn-reflector which D. C. Hogg had begun. Among our astronomical projects for 7 cm were absolute intensity measurements of several traditional astronomical calibration sources and a series of sweeps of the Milky Way to extend my thesis work. In the course of this work we planned to check out our capability of measuring the halo radiation of our Galaxy away from the Milky Way. Existing low frequency measurements indicated that the brightness temperature of the halo would be less than 0.1 K at 7 cm. Thus, a background measurement at 7 cm should produce a null result and would be a good check of our measuring ability.

After completing this program of measurements at 7 cm, we planned to build a similar radiometer at 21 cm. At that wavelength the galactic halo should be bright enough for detection, and we would also observe the 21 cm line of neutral hydrogen atoms. In addition, we planned a number of hydrogen-line projects including an extension of the measurements of Arno's thesis, a search for hydrogen in clusters of galaxies.

At the time we were building the 7-cm radiometer John Bolton visited us and we related our plans and asked for his comments. He immediately selected the most difficult one as the most important: the 21 cm background measurement. First, however, we had to complete the observations at 7 cm.

IV. RADIOMETER SYSTEM

We wanted to make accurate measurements of antenna temperatures. To do this we planned to use the radiometer to compare the antenna to a reference source, in this case, a radiator in liquid helium. I built a switch

which would connect the maser amplifier either to the antenna or to Arno's helium-cooled reference noise source⁵(cold load). This would allow an accurate comparison of the equivalent temperature of the antenna to that of the cold load, since the noise from the rest of the radiometer would be constant during switching. A diagram of this calibration system⁶ is shown in Figure 3 and its operation is described below.

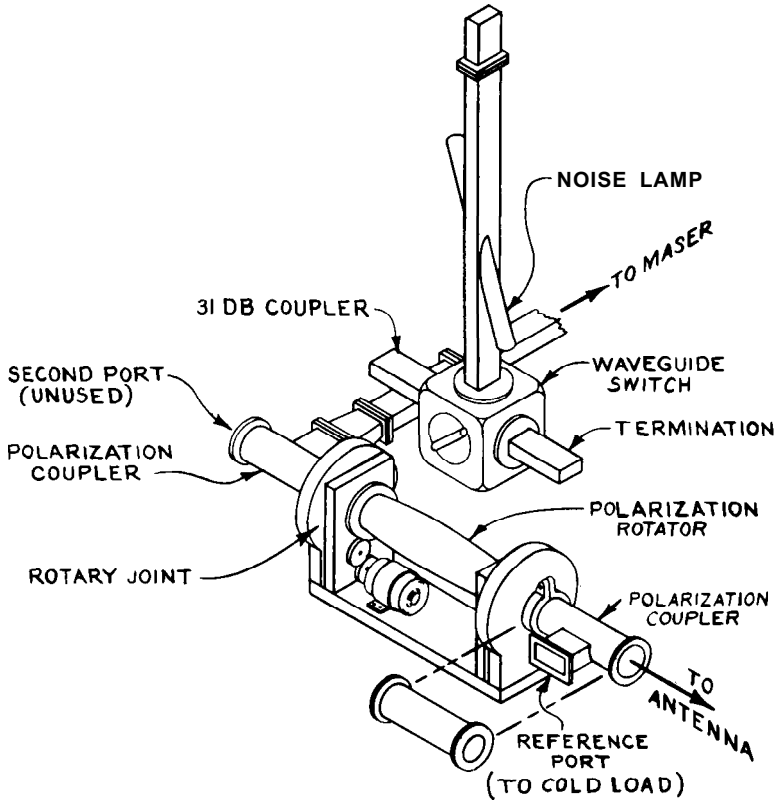

Fig. 3 The switching and calibration system of our 7.35 cm radiometer. The reference port was normally connected to the helium cooled reference source through a noise adding attenuator.

a. Switch

The switch for comparing the cold load to the antenna consists of the two polarization couplers and the polarization rotator shown in Fig. 3. This type of switch had been used by D. H. Ring in several radiometers at Holmdel. It had the advantage of stability, low loss, and small reflections. The circular waveguide coming from the antenna contains the two orthogonal modes of polarization received by the antenna. The first polarization coupler reflected one mode of linear polarization back to the antenna and substituted the signal from the cold load for it in the waveguide going to the rotator. The second polarization coupler took one of the two modes of linear polarization coming from the polarization rotator and coupled it to the rectangular (single-mode) waveguide going to the maser. The polarization rotator is the microwave equivalent of a half-wave plate in optics. It is a

piece of circular waveguide which has been squeezed in the middle so that the phase shifts for waves traveling through it in its two principal planes of linear polarization differ by 180 degrees. By mechanically rotating it, the polarization of the signals passing through it can be rotated. Thus either the antenna or cold load could be connected to the maser.

This type of switch is not inherently symmetric, but has very low loss and is stable so that its asymmetry of .05 K was accurately measured and corrected for.

b. Reference Noise Source

A drawing of the liquid-helium cooled reference noise source is shown in Figure 4. It consists of a 122 cm piece of 90 percent-copper brass waveguide connecting a carefully matched microwave absorber in liquid He to a room-temperature flange at the top. Small holes allow liquid helium to fill the bottom section of waveguide so that the absorber temperature could be known, while a mylar window at a 30° angle keeps the liquid out of the rest of the waveguide and makes a low-reflection microwave transition between the two sections of waveguide. Most of the remaining parts are for the cryogenics. The gas baffles make a counter-flow heat exchanger between the waveguide and the helium gas which has boiled off, greatly extending the time of operation on a charge of liquid helium. Twenty liters of liquid helium cooled the cold load and provided about twenty hours of operation.

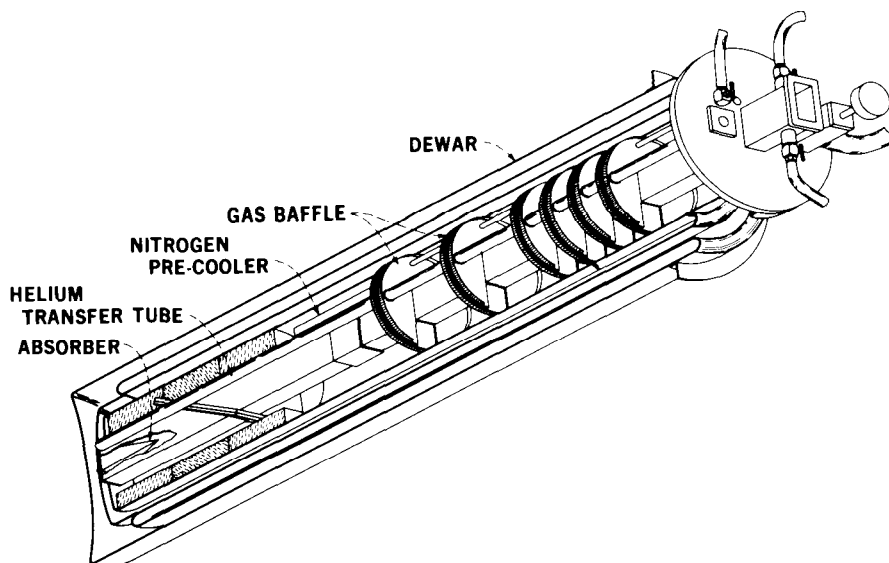

Fig. 4 The Helium Cooled Reference Noise Source.

Above the level of the liquid helium, the waveguide walls were warmer than 4.2 K. Any radiation due to the loss in this part of the waveguide would raise the effective temperature of the noise source above 4.2 K and

must be accounted for. To do so we monitored the temperature distribution along the waveguide with a series of diode thermometers and calculated the contribution of each section of the waveguide to the equivalent temperature of the reference source. When first cooled down, the calculated total temperature of the reference noise source was about 5 K, and after several hours when the liquid helium level was lower, it increased to 6 K. As a check of this calibration procedure, we compared the antenna temperature (assumed constant) to our reference noise source during this period, and found consistency to within 0.1 K.

c. Scale Calibration

A variable attenuator normally connected the cold load to the reference port of the radiometer. This device was at room temperature so noise could be added to the cold load port of the switch by increasing its attenuation. It was calibrated over a range of 0.11 dB which corresponds to 7.4 K of added noise.

Also shown in Fig. 3 is a noise lamp (and its directional coupler) which was used as a secondary standard for our temperature scale.

d. Radiometer Backend

Signals leaving the maser amplifier needed to be further amplified before detection so that their intensity could be measured accurately. The remainder of our radiometer consisted of a down converter to 70 MHz followed by I. F. amplifiers, a precision variable attenuator and a diode detector. The output of the diode detector was amplified and went to a chart recorder.

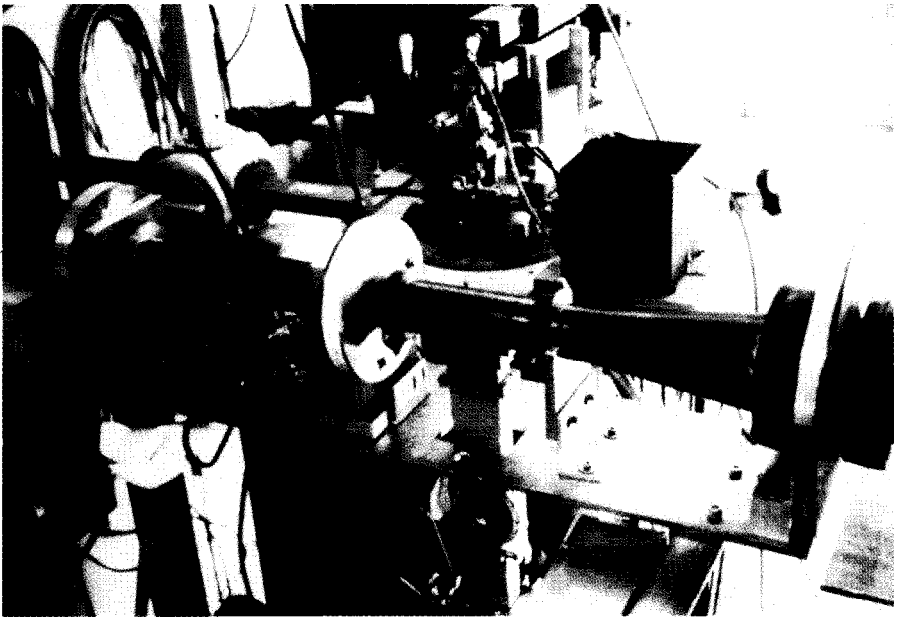

Fig. 5 Our 7.35 cm radiometer installed in the cab of the 20 foot horn-reflector.

e. Equipment Performance

Our radiometer equipment installed in the cab of the 20-foot horn-reflector is shown in Fig. 5. The flange at the far right is part of the antenna and rotates in elevation angle with it. It was part of a double-choke joint which allowed the rest of the equipment to be fixed in the cab while the antenna rotated. The noise contribution of the choke-joint could be measured by clamping it shut and was found to be negligible. We regularly measured the reflection coefficient of the major components of this system and kept it below 0.03 percent, except for the maser whose reflection could not be reduced below 1 percent. Since all ports of our waveguide system were terminated at a low temperature, these reflections resulted in negligible errors.

V. PRIOR OBSERVATIONS

The first horn-reflector-travelling-wave maser system had been put together by DeGrasse, Hogg, Ohm, and Scovil in 1959⁷ to demonstrate the feasibility of a low-noise, satellite-earth station at 5.31 cm. Even though they achieved the lowest total system noise temperature to date, 18.5 K, they had expected to do better. Fig. 6 shows their system with the noise temperature they assigned to each component. As we have seen in Section IIa,

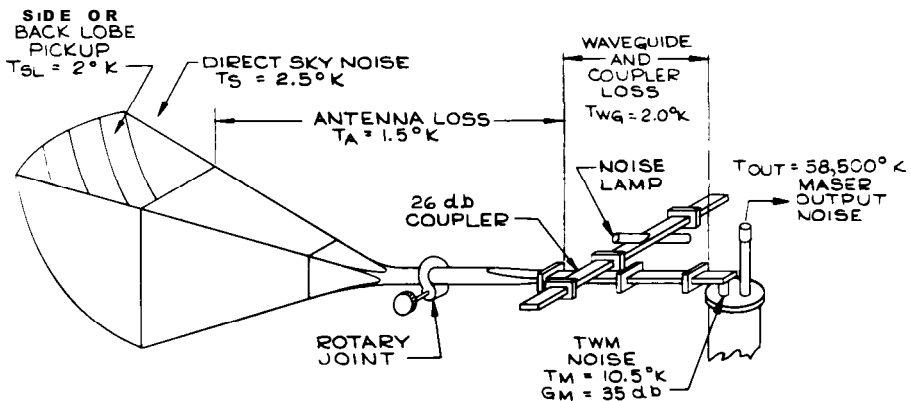

Fig. 6 A diagram of the low noise receiver used by deGrasse, Hogg, Ohm and Scovil to show that very low noise earth stations are possible. Each component is labeled with its contribution to the system noise.

the 2 K they assigned to antenna backlobe pickup is too high. In addition, direct measurements of the noise temperature of the maser gave a value about a degree colder than shown here. Thus their system was about 3 K hotter than one might expect. The component labeled T_s in Fig. 6 is the radiation of the earth's atmosphere when their antenna was aimed straight up. It was measured by a method first reported by R. H. Dicke⁸. (It is interesting that Dicke also reports an upper limit of 20 K for the cosmic microwave background radiation in this paper - the first such report.) If the antenna temperature is measured as a function of the angle above the

horizon at which it is pointing, the radiation of the atmosphere is at a minimum when the antenna is directed straight up. It increases as the antenna points toward the horizon, since the total line of sight through the atmosphere increases. Figure 7 is a chart recording Arno Penzias and I

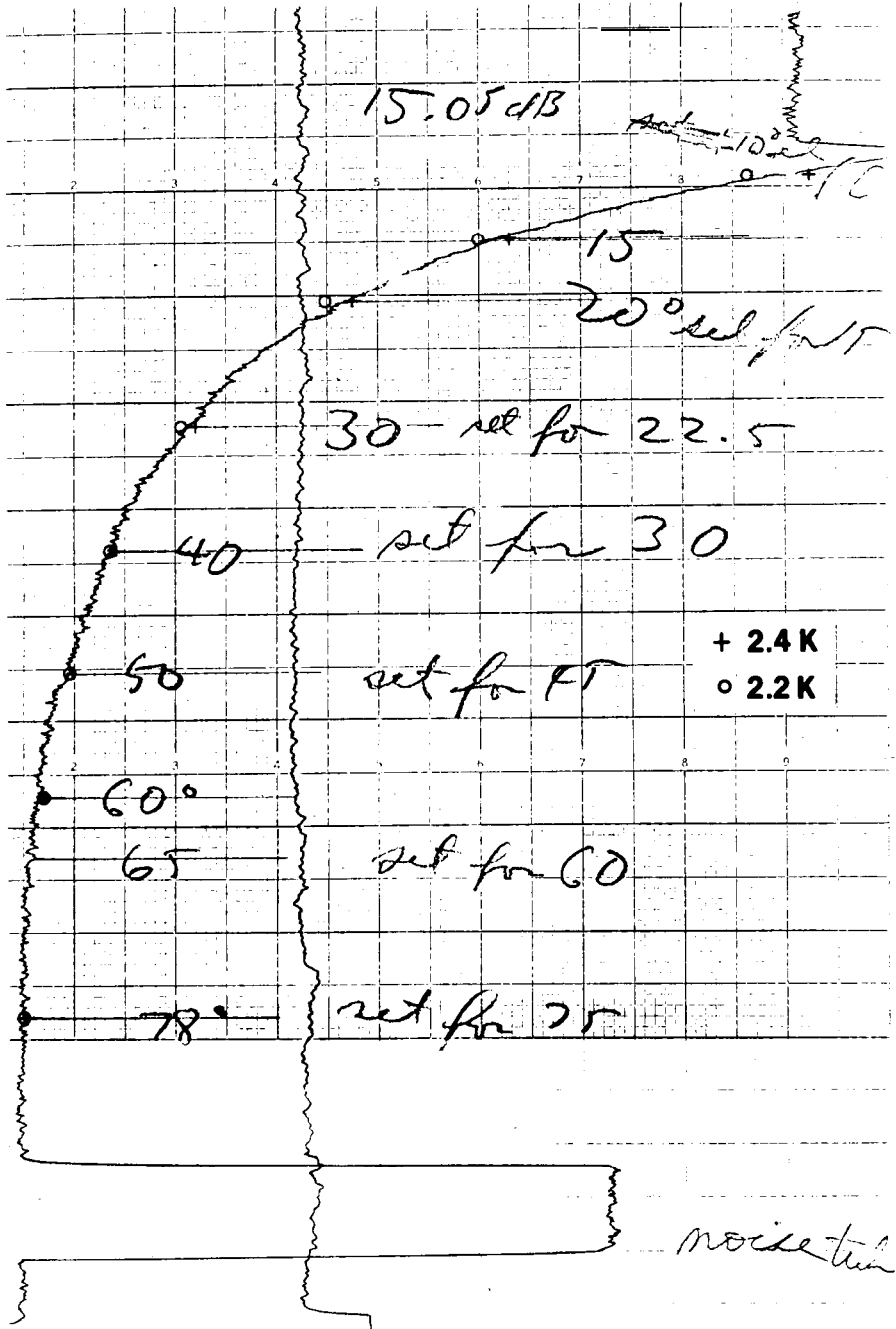

Fig. 7 A measurement of atmospheric noise at 7.35 cm wavelength with theoretical fits to the data for 2.2 and 2.4K Zenith atmospheric radiation.

made with the 20-foot horn-reflector scanning from almost the Zenith down to 10° above the horizon. The circles and crosses are the expected change based on a standard model of the earth's atmosphere for 2.2 and 2.4 K Zenith contribution. The fit between theory and data is obviously good leaving little chance that there might be an error in our value for atmospheric radiation.

Fig. 8 is taken from the paper in which E. A. Ohm⁹ described the receiver on the 20-foot horn reflector which was used to receive signals bounced from the Echo satellite. He found that its system temperature was 3.3 K higher than expected from summing the contributions of the components. As in the previous 5.3 cm work, this excess temperature was smaller

TABLE II – SOURCES OF SYSTEM TEMPERATURE

Source	Temperature
Sky (at zenith)	$2.30 \pm 0.20^\circ\text{K}$
Horn antenna	$2.00 \pm 1.00^\circ\text{K}$
Waveguide (counter-clockwise channel)	$7.00 \pm 0.65^\circ\text{K}$
Maser assembly	$7.00 \pm 1.00^\circ\text{K}$
Converter	$0.60 \pm 0.15^\circ\text{K}$
Predicted total system temperature	$18.90 \pm 3.00^\circ\text{K}$

the temperature was found to vary a few degrees from day to day, but the lowest temperature was consistently $22.2 \pm 2.2^\circ\text{K}$. By realistically assuming that all sources were then contributing their fair share (as is also tacitly assumed in Table II) it is possible to improve the over-all accuracy. The actual system temperature must be in the overlap region of the measured results and the total results of Table II, namely between 20 and 21.9°K . The most likely minimum system temperature was therefore

$$T_{\text{system}} = 21 \pm 1^\circ\text{K}.*$$

The inference from this result is that the “+” temperature possibilities of Table II must predominate.

Fig. 8 An excerpt from E. A. Ohm's article on the Echo receiver showing that his system temperature was 3.3K higher than predicted

than the experimental errors, so not much attention was paid to it. In order to determine the unambiguous presence of an excess source of radiation of about 3 K, a more accurate measurement technique was required. This was achieved in the subsequent measurements by means of a switch and reference noise source combination which communications systems do not have.

VI. OUR OBSERVATIONS

Fig. 9 is a reproduction of the first record we have of the operation of our system. At the bottom is a list of diode thermometer voltages from which we could determine the cold load's equivalent temperature. The recorder trace has power (or temperature) increasing to the right. The middle part of this trace is with the maser switched to the cold load with various settings of the noise adding attenuator. A change of 0.1 dB corresponds to a temperature change of 6.6 K, so the peak-to-peak noise on the trace amounts to less than 0.2 K. At the top of the chart the maser is switched to

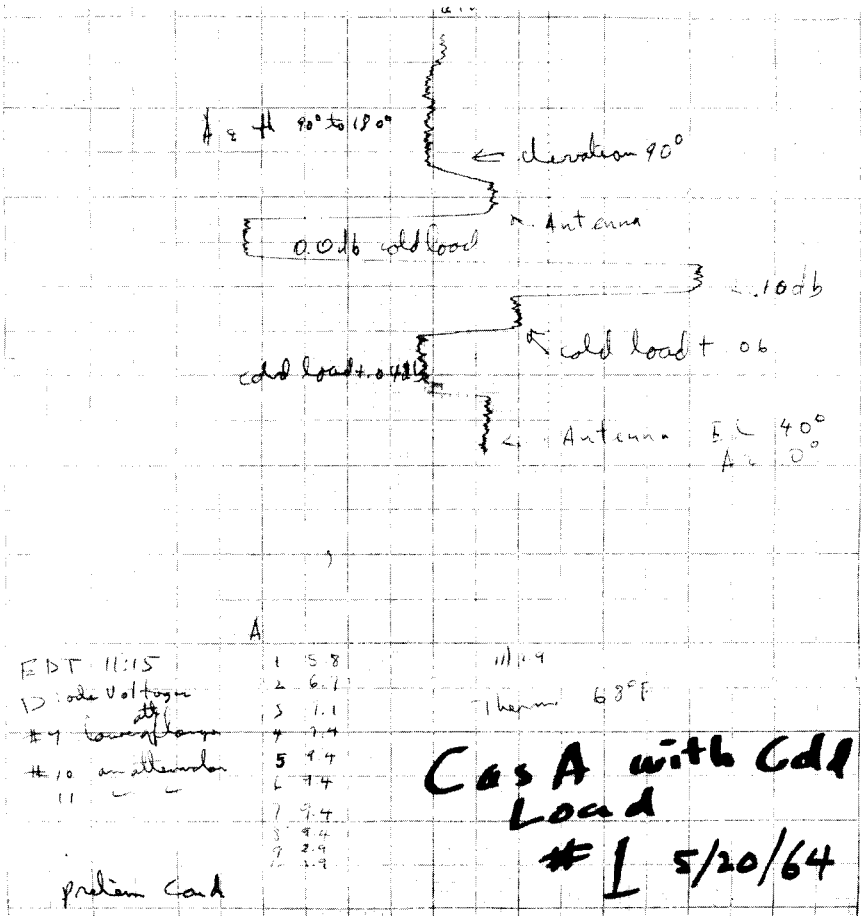

Fig. 9 The first measurement which clearly showed the presence of the microwave background. Noise temperature is plotted increasing to the right. At the top, the antenna pointed at 90° elevation is seen to have the same noise temperature as the cold load with 0.04 db attenuation (about 7.5K). This is considerably above the expected value of 3.3K.

the antenna and has about the same temperature as the cold load plus .04 dB, corresponding to a total of about 7.5 K. This was a troublesome result. The antenna temperature should have been only the sum of the atmospheric contribution (2.3 K) and the radiation from the walls of the antenna and ground (1 K). The excess system temperature found in the previous experiments had, contrary to our expectations, all been in the antenna or beyond. We now had a direct comparison of the antenna with the cold load and had to assign our excess temperature to the antenna whereas in the previous cases only the total system temperature was measured. If we had missed some loss, the cold load might have been warmer than calculated, but it could not be colder than 4.2 K - the temperature of the liquid helium. The antenna was at least 2 K hotter than that. Unless we could understand our "antenna problem" our 21 cm galactic halo experi-

ment would not be possible. We considered a number of possible reasons for this excess and, where warranted, tested for them. These were:

- a. At that time some radio astronomers thought that the microwave absorption of the earth's atmosphere was about twice the value we were using - in other words the "sky temperature" of Figs. 6 and 8 was about 5 K instead of 2.5 K. We knew from our measurement of sky temperature such as shown in Fig. 7 that this could not be the case.
- b. We considered the possibility of man-made noise being picked up by our antenna. However, when we pointed our antenna to New York City, or to any other direction on the horizon, the antenna temperature never went significantly above the thermal temperature of the earth.
- c. We considered radiation from our galaxy. Our measurements of the emission from the plane of the Milky Way were a reasonable fit to the intensities expected from extrapolations of low-frequency measurements. Similar extrapolations for the coldest part of the sky (away from the Milky Way) predicted about .02 K at our wavelength. Furthermore, any galactic contribution should also vary with position and we saw changes only near the Milky Way, consistent with the measurements at lower frequencies.
- d. We ruled out discrete extraterrestrial radio sources as the source of our radiation as they have spectra similar to that of the Galaxy. The same extrapolation from low frequency measurements applies to them. The strongest discrete source in the sky had a maximum antenna temperature of 7 K.

Thus we seemed to be left with the antenna as the source of our extra noise. We calculated a contribution of 0.9 K from its resistive loss using standard waveguide theory. The most lossy part of the antenna was its small diameter throat, which was made of electroformed copper. We had measured similar waveguides in the lab and corrected the loss calculations for the imperfect surface conditions we had found in those waveguides. The remainder of the antenna was made of riveted aluminum sheets, and although we did not expect any trouble there, we had no way to evaluate the loss in the riveted joints. A pair of pigeons was roosting up in the small part of the horn where it enters the warm cab. They had covered the inside with a white material familiar to all city dwellers. We evicted the pigeons and cleaned up their mess, but obtained only a small reduction in antenna temperature.

For some time we lived with the antenna temperature problem and concentrated on measurements in which it was not critical. Dave Hogg and I had made a very accurate measurement of the antenna's gain¹⁰, and Arno and I wanted to complete our absolute flux measurements before disturbing the antenna further.

In the spring of 1965 with our flux measurements finished⁵, we thoroughly cleaned out the 20-foot horn-reflector and put aluminum tape over the riveted joints. This resulted in only a minor reduction in antenna temperature. We also took apart the throat section of the antenna, and checked it, but found it to be in order.

By this time almost a year had passed. Since the excess antenna temperature had not changed during this time, we could rule out two additional sources: 1) Any source in the solar system should have gone through a large change in angle and we should have seen a change in antenna temperature. 2) In 1962, a high-altitude nuclear explosion had filled up the Van Allen belts with ionized particles. Since they were at a large distance from the surface of the earth, any radiation from them would not show the same elevation-angle dependence as the atmosphere and we might not have identified it. But after a year, any radiation from this source should have reduced considerably.

VII. IDENTIFICATION

The sequence of events which led to the unravelling of our mystery began one day when Arno was talking to Bernard Burke of M.I.T. about other matters and mentioned our unexplained noise. Bernie recalled hearing about theoretical work of P. J. E. Peebles in R. H. Dicke's group in Princeton on radiation in the universe. Arno called Dicke who sent a copy of Peebles' preprint. The Princeton group was investigating the implications of an oscillating universe with an extremely hot condensed phase. This hot bounce was necessary to destroy the heavy elements from the previous cycle so each cycle could start fresh. Although this was not a new idea" Dicke had the important idea that if the radiation from this hot phase were large enough, it would be observable. In the preprint, Peebles, following Dicke's suggestion calculated that the universe should be filled with a relic blackbody radiation at a minimum temperature of 10 K. Peebles was aware of Hogg and Semplak's (1961)¹² measurement of atmospheric radiation at 6 cm using the system of DeGrasse et al., and concluded that the present radiation temperature of the universe must be less than their system temperature of 15 K. He also said that Dicke, Roll, and Wilkinson were setting up an experiment to measure it.

Shortly after sending the preprint, Dicke and his coworkers visited us in order to discuss our measurements and see our equipment. They were quickly convinced of the accuracy of our measurements. We agreed to a side-by-side publication of two letters in the *Astrophysical Journal* - a letter on the theory from Princeton¹³ and one on our measurement of excess antenna temperature from Bell Laboratories¹⁴. Arno and I were careful to exclude any discussion of the cosmological theory of the origin of background radiation from our letter because we had not been involved in any of that work. We thought, furthermore, that our measurement was independent of the theory and might outlive it. We were pleased that the mysterious noise appearing in our antenna had an explanation of any kind, especially one with such significant cosmological implications. Our mood, however, remained one of cautious optimism for some time.

VIII. RESULTS

While preparing our letter for publication we made one final check on the antenna to make sure we were not picking up a uniform 3 K from earth. We measured its response to radiation from the earth by using a transmitter located in various places on the ground. The transmitter artificially increased the ground's brightness at the wavelength of our receiver to a level high enough for the backlobe response of the antenna to be measurable. Although not a perfect measure of the structure of the backlobes of an antenna, it was a good enough method of determining their average level. The backlobe level we found in this test was as low as we had expected and indicated a negligible contribution to the antenna temperature from the earth.

The right-hand column of Fig. 10 shows the final results of our measurement. The numbers on the left were obtained later in 1965 with a new throat on the 20-foot horn-reflector. From the total antenna temperature we subtracted the known sources with a result of 3.4 ± 1 K. Since the errors in this measurement are not statistical, we have summed the maximum error from each source. The maximum measurement error of 1 K was considerably smaller than the measured value, giving us confidence in the reality of the result. We stated in the original paper that "This excess temperature is, within the limits of our observations, isotropic, unpolarized, and free of seasonal variations". Although not stated explicitly, our limits on an isotropy and polarization were not affected by most of the errors listed in Fig. 10 and were about 10 percent or 0.3 K.

	New Throat		Old Throat
He Temp.	4.22	4.22	
Calculated Contribution from Cold Load Waveguide Attenuator Setting for Balance	.38	.70 \pm 0.2	
	<u>2.73</u>	<u>2.40 \pm 0.1</u>	
Total C.L.	7.33	7.32 \pm 0.3	6.7 \pm 0.3
Atmosphere	2.3 \pm 0.3		2.3 \pm 0.3
Waveguide and Antenna loss	1.8 \pm 0.3		.9 \pm 0.3
Back lobes	<u>.1 \pm 0.1</u>		<u>.1 \pm 0.1</u>
Total Ant.	4.2 \pm 0.7		3.3 \pm 0.7
Background	3.1 \pm 1		3.4 \pm 1

Fig. 10 Results of our 3965 measurements of the microwave background. "Old Throat" and "New Throat" refer to the original and a replacement throat section for the 20 foot horn-reflector.

At that time the limit we could place on the shape of the spectrum of the background radiation was obtained by comparing our value of 3.5 K with a 74 cm survey of the northern sky done at Cambridge by Pauliny-Toth and Shakeshaft, 1962¹⁵. The minimum temperature on their map was 16 K. Thus the spectrum was no steeper than $\lambda^{0.7}$ over a range of wavelengths that varied by a factor of 10. This clearly ruled out any type of radio source known at that time, as they all had spectra with variation in the range $\lambda^{2.0}$ to $\lambda^{3.0}$. The previous Bell Laboratories measurement at 6 cm ruled out a spectrum which rose rapidly toward shorter wavelengths.

IX. CONFIRMATION

After our meeting, the Princeton experimental group returned to complete their apparatus and make their measurement with the expectation that the background temperature would be about 3 K.

The first confirmation of the microwave cosmic background that we knew of, however, came from a totally different, indirect measurement. This measurement had, in fact, been made thirty years earlier by Adams and Dunhan¹⁶⁻²¹. Adams and Dunhan had discovered several faint optical interstellar absorption lines which were later identified with the molecules CH, CH⁺, and CN. In the case of CN, in addition to the ground state, absorption was seen from the first rotationally excited state. McKellar²² using Adams' data on the populations of these two states calculated that the excitation temperature of CN was 2.3 K. This rotational transition occurs at 2.64 mm wavelength, near the peak of a 3 K black body spectrum. Shortly after the discovery of the background radiation, G. B. Field²³, I. S. Shklovsky²⁴, and P. Thaddeus²⁵ (following a suggestion by N. J. Woolf), independently realized that the CN is in equilibrium with the background radiation. (There is no other significant source of excitation where these molecules are located). In addition to confirming that the background was not zero, this idea immediately confirmed that the spectrum of the background radiation was close to that of a blackbody source for wavelengths larger than the peak. It also gave a hint that at short wavelengths the intensity was departing from the $1/\lambda^2$ dependence expected in the long wavelength (Rayleigh-Jeans) region of the spectrum and following the true blackbody (Planck) distribution. In 1966, Field and Hitchcock²³ reported new measurements using Herbig's plates of ζ Oph and ζ Per obtaining 3.22 ± 0.15 K and 3.0 ± 0.6 K for the excitation temperature. Thaddeus and Clauser²⁵ also obtained new plates and measured 3.75 ± 0.5 K in ζ Oph. Both groups argued that the main source of excitation in CN is the background radiation. This type of observation, taken alone, is most convincing as an upper limit, since it is easier to imagine additional sources of excitation than refrigeration.

In December 1965 Roll and Wilkinson²⁶ completed their measurement of 3.0 ± 0.5 K at 3.2 cm, the first confirming microwave measurement. This was followed shortly by Howell and Shakeshaft's²⁷ value of 2.8 ± 0.6

K at 20.7 cm²² and then by our measurement of $3.2 \text{ K} \pm 1 \text{ K}$ at 21.1 cm²⁸. (Half of the difference between these two results comes from a difference in the corrections used for the galactic halo and integrated discrete sources.) By mid 1966 the intensity of the microwave background radiation had been shown to be close to 3 K between 21 cm and 2.6 mm, almost two orders of magnitude in wavelength.

X. EARLIER THEORY

I have mentioned that the first experimental evidence for cosmic microwave background radiation was obtained (but unrecognized) long before 1965. We soon learned that the theoretical prediction of it had been made at least sixteen years before our detection. George Gamow had made calculations of the conditions in the early universe in an attempt to understand Galaxy formation²⁹. Although these calculations were not strictly correct, he understood that the early stages of the universe had to be very hot in order to avoid combining all of the hydrogen into heavier elements. Furthermore, Gamow and his collaborators calculated that the density of radiation in the hot early universe was much higher than the density of matter. In this early work the present remnants of this radiation were not considered. However in 1949, Alpher and Herman³⁰ followed the evolution of the temperature of the hot radiation in the early universe up to the present epoch and predicted a value of 5 K. They noted that the present density of radiation was not well known experimentally. In 1953 Alpher, Follin, and Herman³¹ reported what has been called the first thoroughly modern analysis of the early history of the universe, but failed to recalculate or mention the present radiation temperature of the universe.

In 1964, Doroshkevich and Novikov^{32,33} had also calculated the relic radiation and realized that it would have a blackbody spectrum. They quoted E. A. Ohm's article on the Echo receiver, but misunderstood it and concluded that the present radiation temperature of the universe is near zero.

A more complete discussion of these early calculations is given in Arno's lecture.³⁴

XI. ISOTROPY

In assigning a single temperature to the radiation in space, these theories assume that it will be the same in all directions. According to contemporary theory, the last scattering of the cosmic microwave background radiation occurred when the universe was a million years old, just before the electrons and nuclei combined to form neutral atoms ("recombination"). The isotropy of the background radiation thus measures the isotropy of the universe at that time and the isotropy of its expansion since then. Prior to recombination, radiation dominated the 'universe and the Jeans mass, or mass of the smallest gravitationally stable clumps was larger than a cluster of Galaxies. It is only in the period following recombination that Galaxies could have formed.

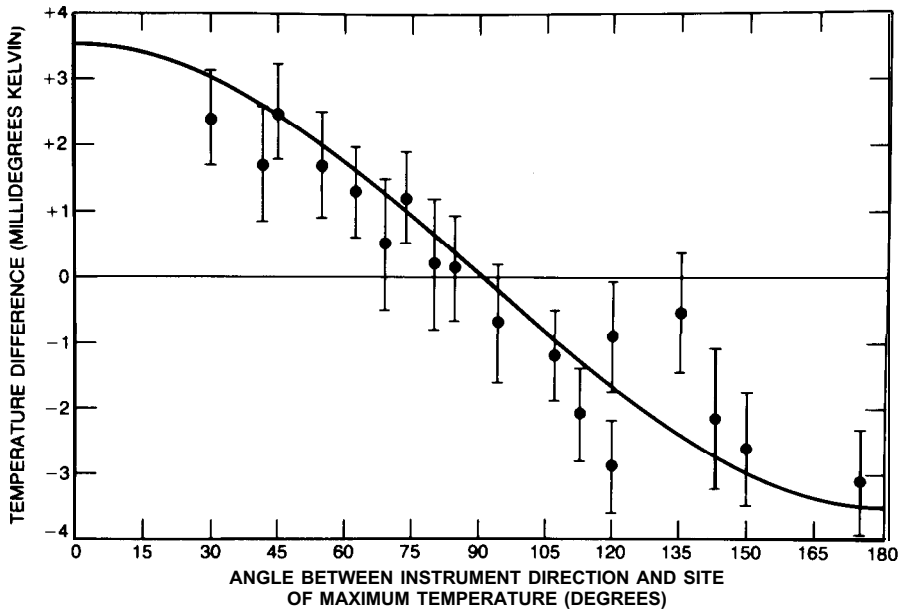

Fig. 11 Results of the large scale isotropy Experiment of Smoot, Gorenstein and Muller showing the clear cosine dependence of brightness expected from the relative velocity of the earth in the background radiation. The shaded area and arrows show the values allowed by the data of Woody and Richards. (This figure is reproduced with permission of Scientific American.)

In 1967 Rees and Sciama³⁵ suggested looking for large scale anisotropies in the background radiation which might have been left over from anisotropies of the universe prior to recombination.

In the same year Wilkinson and Partridge³⁶ completed an experiment which was specifically designed to look for anisotropy within the equatorial plane. They reported a limit of 0.1 percent for a 24 hour asymmetry and a possible 12 hour asymmetry of 0.2 percent. Meanwhile we had re-analyzed an old record covering most of the sky which was visible to us and put a limit of 0.1 K on any large scale fluctuations.³⁷

Since then a series of measurements^{38 39 40} have shown a 24-hour anisotropy due to the earth's velocity with respect to the background radiation. Data from the most sensitive measurement to date⁴¹ are shown in Fig. 11. They show a striking cosine anisotropy with an amplitude of about .003 K, indicating that the background radiation has a maximum temperature in one direction and a minimum in the opposite direction. The generally accepted explanation of this effect is that the earth is moving toward the direction where the radiation is hottest and it is the blue shift of the radiation which increases its measured temperature in that direction. The motion of the sun with respect to the background radiation from the data of Smoot et al. is 390 ± 60 km/s in the direction 10.8^{h} R. A., 5° Dec. The magnitude of this velocity is not a surprise since 300 km/s is the orbital velocity of the sun around our galaxy. The direction, is different, however yielding a peculiar velocity of our galaxy of about 600 km/s. Since other nearby Galaxies; including the Virgo cluster,

have a small velocity with respect to our Galaxy, they have a similar velocity with respect to the matter which last scattered the background radiation. After subtracting the 24-hour anisotropy, one can search the data for more complicated anisotropies to put observational limits on such things as rotation of the universe⁴¹. Within the noise of .001 K, these anisotropies are all zero.

To date, no fine-scale anisotropy has been found. Several early investigations were carried out to discredit discrete source models of the background radiation. In the most sensitive experiment to date, Boynton and Partridge⁴² report a relative intensity variation of less than 3.7×10^{-3} in an 80" Arc beam. A discrete source model would require orders of magnitude more sources than the known number of Galaxies to show this degree of smoothness.

It has also been suggested by Sunyaev and Zel'dovich⁴³ that there will be a reduction of the intensity of the background radiation from the direction of clusters of galaxies due to inverse Compton scattering by the electrons in the intergalactic gas. This effect which has been found by Birkinshaw and Gull⁴⁴, provides a measure of the intergalactic gas density in the clusters and may give an alternate measurement of Hubble's constant.

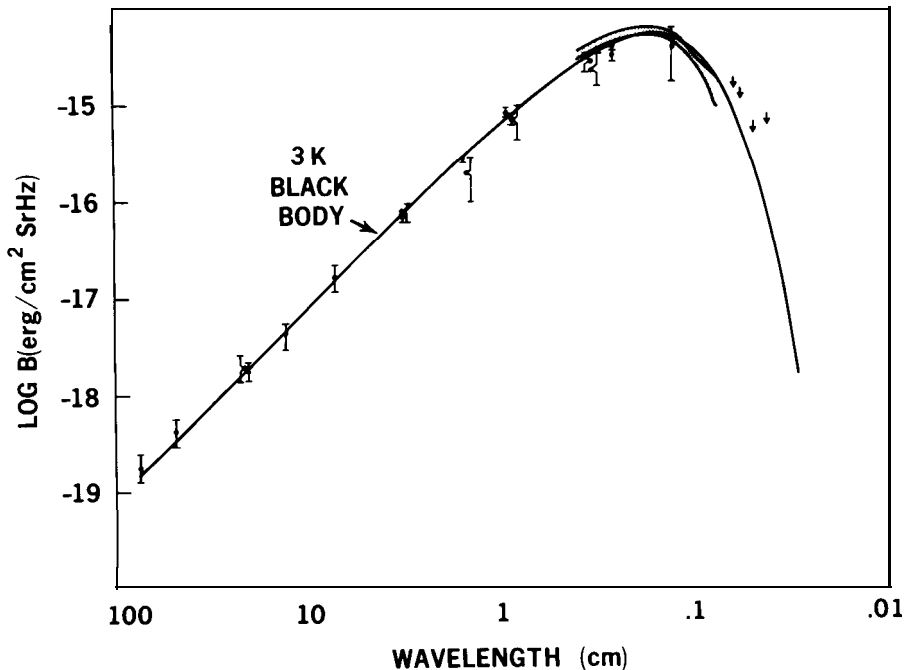

Fig. 12 Measurements of the spectrum of the cosmic microwave background radiation.

XII. SPECTRUM

Since 1966, a large number of measurements of the intensity of the background radiation have been made at wavelengths from 74 cm to 0.5 mm. Measurements have been made from the ground, mountain tops,

airplanes, balloons, and rockets. In addition, the optical measurements of the interstellar molecules have been repeated and we have observed their millimeter-line radiation directly to establish the equilibrium of the excitation of their levels with the background radiation⁴⁵. Fig. 12 is a plot of most of these measurements⁴⁶. An early set of measurements from Princeton covered the range 3.2 to .33 cm showing tight consistency with a 2.7 K black body⁴⁷⁻⁵⁰. A series of rocket and balloon measurements in the millimeter and submillimeter part of the spectrum have converged on about 3 K. The data of Robson, et al.⁵¹ and Woody and Richards⁵² extend to 0.8 mm, well beyond the spectral peak. The most recent experiment, that of D. Woody and P. Richards, gives a close fit to a 3.0 K spectrum out to 0.8 mm wavelength with upper limits at atmospheric windows out to 0.4 mm. This establishes that the background radiation has a blackbody spectrum which would be quite hard to reproduce with any other type of cosmic source. The source must have been optically thick and therefore must have existed earlier than any of the other sources, which can be observed.

The spectral data are now almost accurate enough for one to test for systematic deviations from a single-temperature blackbody spectrum which could be caused by minor deviations from the simplest cosmology. Danese and DeZotti⁵³ report that except for the data of Woody and Richards, the spectral data of Fig. 12 do not show any statistically significant deviation of this type.

XIII. CONCLUSION

Cosmology is a science which has only a few observable facts to work with. The discovery of the cosmic microwave background radiation added one - the present radiation temperature of the universe. This, however, was a significant increase in our knowledge since it requires a cosmology with a source for the radiation at an early epoch and is a new probe of that epoch. More sensitive measurements of the background radiation in the future will allow us to discover additional facts about the universe.

XIV. ACKNOWLEDGMENTS

The work which I have described was done with Arno A. Penzias. In our fifteen years of partnership he has been a constant source of help and encouragement. I wish to thank W. D. Langer and Elizabeth Wilson for carefully reading the manuscript and suggesting changes.

REFERENCES

1. A more complete discussion of radio telescope antennas and receivers may be found in several text books. Chapters 6 and 7 of J. D. Kraus "Radio Astronomy", 1966, McGraw-Hill are good introductions to the subjects.
2. Crawford, A. B. Hogg, D. C. and Hunt, L. E. 1961, Bell System Tech. J., 40, 1095.

3. DeGrasse, R. W. Schultr-DuBois, E. O. and Scovil, H. E. D. BSTJ 38, 30.5.
4. Tabor, W. J. and Sibilia, J. 1'. 1963, Bell System Tech. J., 42, 1863.
5. Penzias, A. A. 1965, Rev. Sci. Instr., 36. 68.
6. Penzias, A. A. and Wilson, R. W. 1965 Astrophysical Journal 142. 1149.
7. DeGrasse, R. W. Hogg, D. C. Ohm, E. A. and Scovil, H. E. D. 1950, Proceedings of the National Electronics Conference. 15, 370.
8. Dicke, R. Beringer R. Kyhl, R. L. and Vane, A. V. Phys. Rev. 70, 340 (1046).
9. Ohm, E. A. 1961 BSTJ, 40, 1065.
10. Hogg, D. C. and Wilson, R. W. Bell system Tech J., 44, 1019.
11. c.f. F. Hoyle and R. J. Taylor 1964. Nature 203, 1108. A less explicit discussion of the same notion occurs in [29].
12. Hogg, D. C. and Semplak, R. A. 1961, Bell System Technical Journal. 40, 1331 .
13. Dicke, R. H. Peebles, P. J. E. Roll, P. G. and Wilkinson, D. T. 1965, Ap. J., 142. 4 14.
14. Penzias, A. A. and Wilson R. W. 1965, Ap. J.. 142, 420.
15. Pauliny-Toth, I. I. K. and Shakeshaft, J. R. 1962, M. N. RAS.. 124, 61.
16. Adams, W. S. 1941, Ap. J. 93, 11.
17. Adams, W. S. 1943, Ap. J., 97, 105.
18. Dunham, T. Jr. 1937, PASP, 49, 26.
19. Dunham, T. Jr. 1939, Proc. Am. Phil. Soc., 81, 277.
20. Dunham, T. Jr. 1941, Publ. Am. Astron. Soc., 10, 123.
21. Dunham, T. Jr. and W. S. Adams 1937, Publ. Am. Astron. Soc., 9, 5.
22. McKellar, A. 1941, Publ. Dominion Astrophysical Observatory Victoria B. C. 7, 251.
23. G. B. Field, G. H. Herbig and J. L. Hitchcock, talk at the American Astronomical Society Meeting, 22-29 December 1965, Astronomical Journal 1966, **71**. 161; G. B. Field and J. L. Hitchcock, 1966, Phys. Rev. Lett. **16**, **8** 17.
24. Shklovsky, I. S. 1966, Astron. Circular No. 364, Acad. Sci. USSR.
25. Thaddeus, P. and Clauser, J. F. 1966, Phys. Rev. Lett. **16**, **8** 19.
26. Roll, P. G. and Wilkinson, D. T. 1966, Physical Review Letters, **16**, **405**.
27. Howell, T. F. and Shakeshaft, J. R. 1966, Nature 210, 138.
28. Penzias, A. A. and Wilson R. W. 1967, Astron. J. 72, 315.
29. Gamow, G. 1948, Nature 162 680.
30. Alpher, R. A. and Herman, R. C. 1949, Phys. Rev., 75, 1089.
31. Alpher, R. A. Follin, J. W. and Herman, R. C. 1953, Phys. Rev., 92, 1347.
32. Doroshkevich, A. G. and Novikov. I. D. 1964 Dokl. Akad. Navk. SSR 154, 809.
33. Doroshkevich, A. G. and Novikov, I. D. 1964 Sov. Phys. Dokl. 9, 111 .
34. Penzias, A. A. *The Origin of the Elements*, Nobel Prize lecture 1978.
35. Rees, M. J. and Sciama, D. W. 1967, Nature, 213, 374.
36. Partridge, R. B. and Wilkinson, D. T. 1967, Nature, **215**, 7 19.
37. Wilson, R. W. and Penzias, A. A. 1967, Science **156**, **1100**.
38. Conklin, E. K. 1969, Nature, 222, 97 I.
39. Henry, P. S. 1971, Nature, 231, 516.
40. Corey, B. E. and Wilkinson, D. T. 1976, Bull. Astron. Astrophys. Soc., 8, 351.
41. Smoot, G. F. Gorenstein, M. V. and Muller, R. A. 1977, Phys. Rev. Lett., 39, 898.
42. Boynton, P. E. and Partridge, R. B. 1973, Ap. J., 181, 243.
43. Sunyaev, R. A. and Zel'dovich, Ya B 1972, Comments Astrophys. Space Phys., 4, 173.
44. Birkinshaw, M. and Gull, S. F. 1978, Nature 275 40.
45. Penzias, A. A. Jefferts, K. B. and Wilson, R. W'. 1972, Phys. Rev. Letters, 28, 772.
46. The data in Fig. 11 are all referenced by Danese and Dezotti⁴⁵ except for the 13 cm measurement of T. Osho 1975, IEEE Trans on Instrumentation and Meas. 24 174. I have used the millimeter measurements of Woody and Richards⁴⁶ and left off those of Robson et al⁴⁷ to avoid confusion.
47. Wilkinson, D. J. 1967, Phys. Rev. Letters. **19**, 1195.
48. Stokes, R. A. Partridge, R. B. and Wilkinson, D. J. 1967. Phys. Rev. Letters, 19, 1199.
49. Boynton, P. E. Stokes, R. A. and Wilkinson, D. J. 1968, Phys. Rev. Letters, 21, 462.
50. Boynton, P. E. and Stokes, R. A. 1974, Nature, 247, 528.
51. Robson, E. I. Vickers, D. G. Huizinga, J. S. Beckman, J. E. and Clegg, P. E. 1974, Nature **251**, 591.
52. Woody, D. P. and Richards, P. L. Private communication.
53. Danese, L. and DeZotti, G. 1978, Astron. and Astrophys.. 68, 157.